

R150/R230/R300

Operator's Manual



CMW®

Issue 1.6

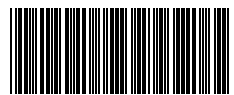

053-1173

Overview



Chapter Contents

Serial Number Location	2
Intended Use	3
Equipment Modification	3
Unit Components	4
Operator Orientation	4
About This Manual	4
• Bulleted Lists5
• Numbered Lists5
• "Continued" Indicators5

Serial Number Location

Record serial numbers and date of purchase in spaces provided. Power unit serial number is located as shown.

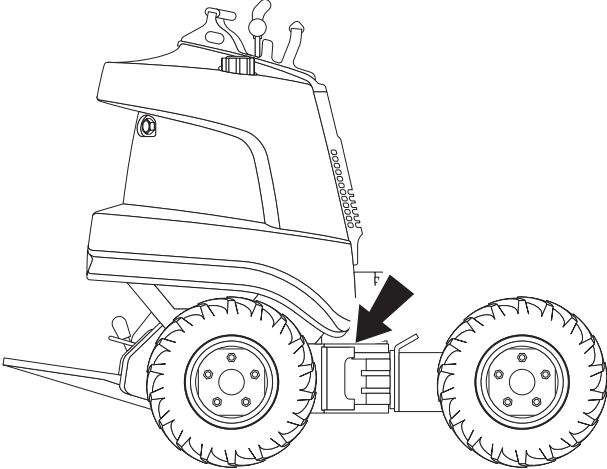

t22om024a.eps

Date of manufacture	
Date of purchase	
Power unit serial number	
Front end serial numbers	



Intended Use

The Zahn line consists of three versatile performers. The R150 is configured as a dedicated trencher. The R230 and R300 units can be configured as dedicated trenchers or they can be configured with an InterChange connection to allow them to accept a variety of front ends. Available interchangeable front ends include a trencher, vibratory plow, dumper, tool carrier, backhoe, stump grinder and tiller. Contact your Ditch Witch dealer for a complete list of available front ends.

The unit is designed for operation in temperatures typically experienced in earth moving and construction work environments. Provisions may be required to operate in extreme temperatures. Contact your Ditch Witch dealer. Use in any other way is considered contrary to the intended use.

Zahn R150, R230 and R300 units should be used with genuine Ditch Witch front ends, attachments and components. They should be operated, serviced, and repaired only by persons familiar with their particular characteristics and acquainted with the relevant safety procedures.

Equipment Modification

This equipment was designed and built in accordance with applicable standards and regulations. Modification of equipment could mean that it will no longer meet regulations and may not function properly or in accordance with the operating instructions. Modification of equipment should only be made by competent personnel possessing knowledge of applicable standards, regulations, equipment design functionality/requirements and any required specialized testing.

Unit Components

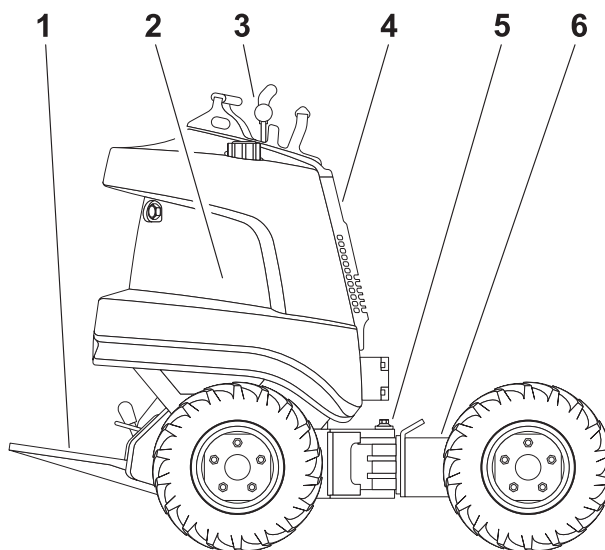

t22om026a.eps

- | | |
|-----------------------|---|
| 1. operator platform | 4. front end manifold |
| 2. engine compartment | 5. articulation joint |
| 3. control console | 6. InterChange connection (R230 and R300) |

Operator Orientation

- | | |
|------------------|-----------------|
| 1. Front of unit | 3. Rear of unit |
| 2. Right of unit | 4. Left of unit |

Right and left sides of machine are determined by facing front of unit while standing on platform.

NOTICE: Operate unit only while standing on platform.

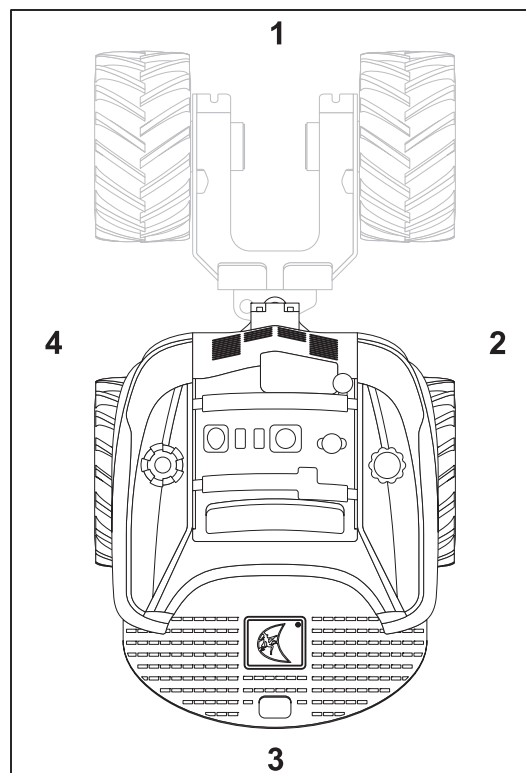

t22om027a.eps

About This Manual



This manual contains information for the proper use of this machine. See **Operation Overview** for basic operating procedures. Cross references such as "See page 50" will direct you to detailed procedures.

Bulleted Lists

Bulleted lists provide helpful or important information or contain procedures that do not have to be performed in a specific order.

Numbered Lists

Numbered lists contain illustration callouts or list steps that must be performed in order.

"Continued" Indicators



indicates that a procedure is continued on the next page.

Foreword



This manual is an important part of your equipment. It provides safety information and operation instructions to help you use and maintain your Ditch Witch equipment.

Read this manual before using your equipment. Keep it with the equipment at all times for future reference. If you sell your equipment, be sure to give this manual to the new owner.

If you need a replacement copy, contact your Ditch Witch dealer or download it at www.ditchwitch.com. If you need assistance in locating a dealer, visit our website or write to the following address:

The Charles Machine Works, Inc.
Attn: Marketing Department
PO Box 66
Perry, OK 73077-0066
USA

The descriptions and specifications in this manual are subject to change without notice. The Charles Machine Works, Inc. reserves the right to improve equipment. Some product improvements may have taken place after this manual was published. For the latest information on Ditch Witch equipment, see your Ditch Witch dealer.

Thank you for buying and using Ditch Witch equipment.

**R150/R230/R300
Operator's Manual**

Issue number 1.6/OM-9/09

Part number 053-1173

**Copyright 2007, 2008, 2009
by The Charles Machine Works, Inc.**



, Ditch Witch, CMW, AutoCrowd, Jet Trac, Roto Witch, Subsite, Fluid Miser, Power Pipe, Super Witch, Pierce Arrow, The Underground, The Underground Authority Worldwide, and Zahn are registered trademarks of The Charles Machine Works, Inc.

This product is covered by the following patent: **U.S. 7,621,366**; other U.S. and foreign patents pending.

Contents



	Overview machine serial number, information about the type of work this machine is designed to perform, basic machine components, and how to use this manual	1
	Foreword part number, revision level, and publication date of this manual, and factory contact information	7
	Safety machine safety alerts and emergency procedures	11
	Controls machine controls, gauges, and indicators and how to use them	21
	Prepare procedures for inspecting and classifying the jobsite, planning the installation path (if needed), preparing the jobsite for work, and connecting front ends	33
	Drive procedures for startup, cold start, driving, and shutdown	39
	Transport procedures for lifting, hauling, and towing	43
	Trench procedures for trenching	51
	Systems and Equipment chain, teeth, sprockets, and optional equipment	55
	Complete the Job procedures for restoring the jobsite and rinsing and storing equipment	59
	Service service intervals and instructions for this machine including lubrication, replacement of wear items, and basic maintenance	61
	Specifications machine specifications including weights, measurements, power ratings, and fluid capacities	81



Support

the warranty policy for this machine, and procedures for obtaining warranty consideration and training

99



Service Record

a record of major service performed on the machine

103

Safety

Chapter Contents

- Guidelines 12**
- Safety Alert Classifications 13**
- Safety Alerts 14**
- Emergency Procedures 17**
- Electric Strike Description17
- If an Electric Line is Damaged18
- If a Gas Line is Damaged18
- If a Fiber Optic Cable is Damaged19
- If Machine Catches on Fire19



Guidelines

Follow these guidelines before operating any jobsite equipment:

- Complete proper training and read operator's manual before using equipment.
- Contact your local One-Call (811 in USA) or the One-Call referral number (888-258-0808 in USA and Canada) to have underground utilities located before digging. Also contact any utilities that do not participate in the One-Call service.
- Classify jobsite based on its hazards and use correct tools and machinery, safety equipment, and work methods for jobsite.
- Mark jobsite clearly and keep spectators away.
- Wear personal protective equipment.
- Review jobsite hazards, safety and emergency procedures, and individual responsibilities with all personnel before work begins. Safety videos are available at www.ditchwitch.com and from Ditch Witch dealers.
- Replace missing or damaged safety shields and safety signs.
- Use equipment carefully. Stop operation and investigate anything that does not look or feel right.
- Do not operate unit where flammable gas is present.
- Contact your Ditch Witch dealer if you have any question about operation, maintenance, or equipment use.

Safety Alert Classifications

These classifications and the icons defined on the following pages work together to alert you to situations which could be harmful to you, jobsite bystanders or your equipment. When you see these words and icons in the book or on the machine, carefully read and follow all instructions. **YOUR SAFETY IS AT STAKE.**



Watch for the three safety alert levels: **DANGER**, **WARNING** and **CAUTION**. Learn what each level means.

 **DANGER** indicates an imminently hazardous situation which, if not avoided, will result in death or serious injury.

 **WARNING** indicates a potentially hazardous situation which, if not avoided, could result in death or serious injury.

 **CAUTION** indicates a potentially hazardous situation which, if not avoided, may result in minor or moderate injury.

Watch for two other words: **NOTICE** and **IMPORTANT**.

NOTICE can keep you from doing something that might damage the machine or someone's property. It can also alert you against unsafe practices.

IMPORTANT can help you do a better job or make your job easier in some way.

Safety Alerts

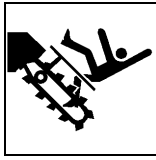

⚠ DANGER

Moving digging teeth will kill you or cut off arm or leg. Stay away.



⚠ DANGER

Turning shaft will kill you or crush arm or leg. Stay away.

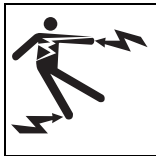

⚠ DANGER

Electric shock. Contacting electric lines will cause death or serious injury. Know location of lines and stay away.

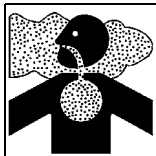

⚠ DANGER

Deadly gases. Lack of oxygen or presence of gas will cause sickness or death. Provide ventilation.

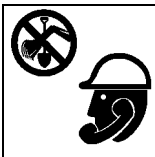

⚠ WARNING

Jobsite hazards could cause death or serious injury. Use correct equipment and work methods. Use and maintain proper safety equipment.



⚠ WARNING

Crushing weight could cause death or serious injury. Use proper procedures and equipment or stay away.



⚠ WARNING

Moving parts could cut off hand or foot. Stay away.

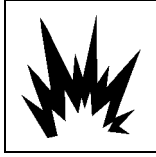

⚠ WARNING Explosion possible. Serious injury or equipment damage could occur. Follow directions carefully.

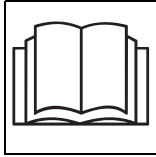

⚠ WARNING Incorrect procedures could result in death, injury, or property damage. Learn to use equipment correctly.

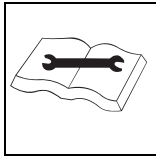

⚠ WARNING Improper control function could cause death or serious injury. If control does not work as described in instructions, stop machine and have it serviced.

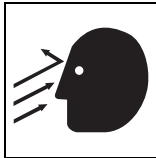

⚠ WARNING Looking into fiber optic cable could result in permanent vision damage. Do not look into ends of fiber optic or unidentified cable.

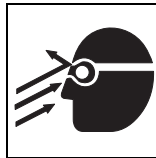

⚠ WARNING Pressurized fluid or air could pierce skin and cause injury or death. Stay away.



⚠ WARNING Runaway possible. Machine could run over you or others. Learn how to use all controls. Start and operate only from operator's position.



⚠ WARNING Fire or explosion possible. Fumes could ignite and cause burns. No smoking, no flame, no spark.



⚠ WARNING Moving traffic - hazardous situation. Death or serious injury could result. Avoid moving vehicles, wear high visibility clothing, post appropriate warning signs.





⚠ WARNING Tipover possible. Machine can tip over and crush you.

- Always operate with load end uphill.
- Always carry load low. High load can cause tipping, loss of load or loss of visibility.
- Never jerk control levers. Use a steady even motion.



⚠ CAUTION Flying objects may cause injury. Wear hard hat and safety glasses.



⚠ CAUTION Hot parts may cause burns. Do not touch until cool.

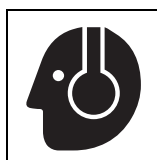

⚠ CAUTION Exposure to high noise levels may cause hearing loss. Wear hearing protection.



⚠ CAUTION Fall possible. Slips or trips may result in injury. Keep area clean.

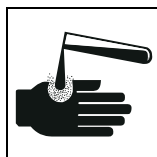

⚠ CAUTION Battery acid may cause burns. Avoid contact.



⚠ CAUTION Improper handling or use of chemicals may result in illness, injury, or equipment damage. Follow instructions on labels and in material safety data sheets (MSDS).

Emergency Procedures

Before operating any equipment, review emergency procedures and check that all safety precautions have been taken.

EMERGENCY SHUTDOWN: Release all controls (including cruise control pedal) and turn ignition switch to OFF.



Electric Strike Description

When working near electric cables, remember the following:

- Electricity follows all paths to ground, not just path of least resistance.
- Pipes, hoses, and cables will conduct electricity back to all equipment.
- Low voltage current can injure or kill. Almost one-third of work-related electrocutions result from contact with less than 440 volts.

Most electric strikes are not noticeable, but indications of a strike include:

- power outage
- smoke
- explosion
- popping noises
- arcing electricity

If any of these occur, assume an electric strike has occurred.

If an Electric Line is Damaged

If you suspect an electric line has been damaged and you are **on platform**, DO NOT MOVE. Remain on platform and take the following actions. The order and degree of action will depend upon the situation.

- Warn people nearby that an electric strike has occurred. Instruct them to leave the area and contact utility.
- Raise front end and attachments and drive from immediate area.
- Contact utility company to shut off power.
- Do not return to jobsite or allow anyone into area until given permission by utility company.

If you suspect an electric line has been damaged and you are **off platform**, DO NOT TOUCH UNIT. Take the following actions. The order and degree of action will depend upon the situation.

- LEAVE AREA. The ground surface may be electrified, so take small steps with feet close together to reduce the hazard of being shocked from one foot to the other. For more information, contact your Ditch Witch dealer.
- Contact utility company to shut off power.
- Do not return to jobsite or allow anyone into area until given permission by utility company.

If a Gas Line is Damaged

If you suspect a gas line has been damaged, take the following actions. The order and degree of action will depend on the situation.

- Immediately shut off engine(s), if this can be done safely and quickly.
- Remove any ignition source(s), if this can be done safely and quickly.
- Warn others that a gas line has been cut and that they should leave the area.
- Leave jobsite as quickly as possible.
- Immediately call your local emergency phone number and utility company.
- If jobsite is along street, stop traffic from driving near jobsite.
- Do not return to jobsite until given permission by emergency personnel and utility company.

If a Fiber Optic Cable is Damaged

Do not look into cut ends of fiber optic or unidentified cable. Vision damage can occur.

If Machine Catches on Fire

Perform emergency shutdown procedure and then take the following actions. The order and degree of action will depend on the situation.

- Immediately move battery disconnect switch (if equipped) to disconnect position.
- If fire is small and fire extinguisher is available, attempt to extinguish fire.
- If fire cannot be extinguished, leave area as quickly as possible and contact emergency personnel.



Controls

Chapter Contents

Gauges and Indicators 22

Controls 24

- R150/R150E 24
- R230/R300 28
- R150/R230/R300 32



Gauges and Indicators

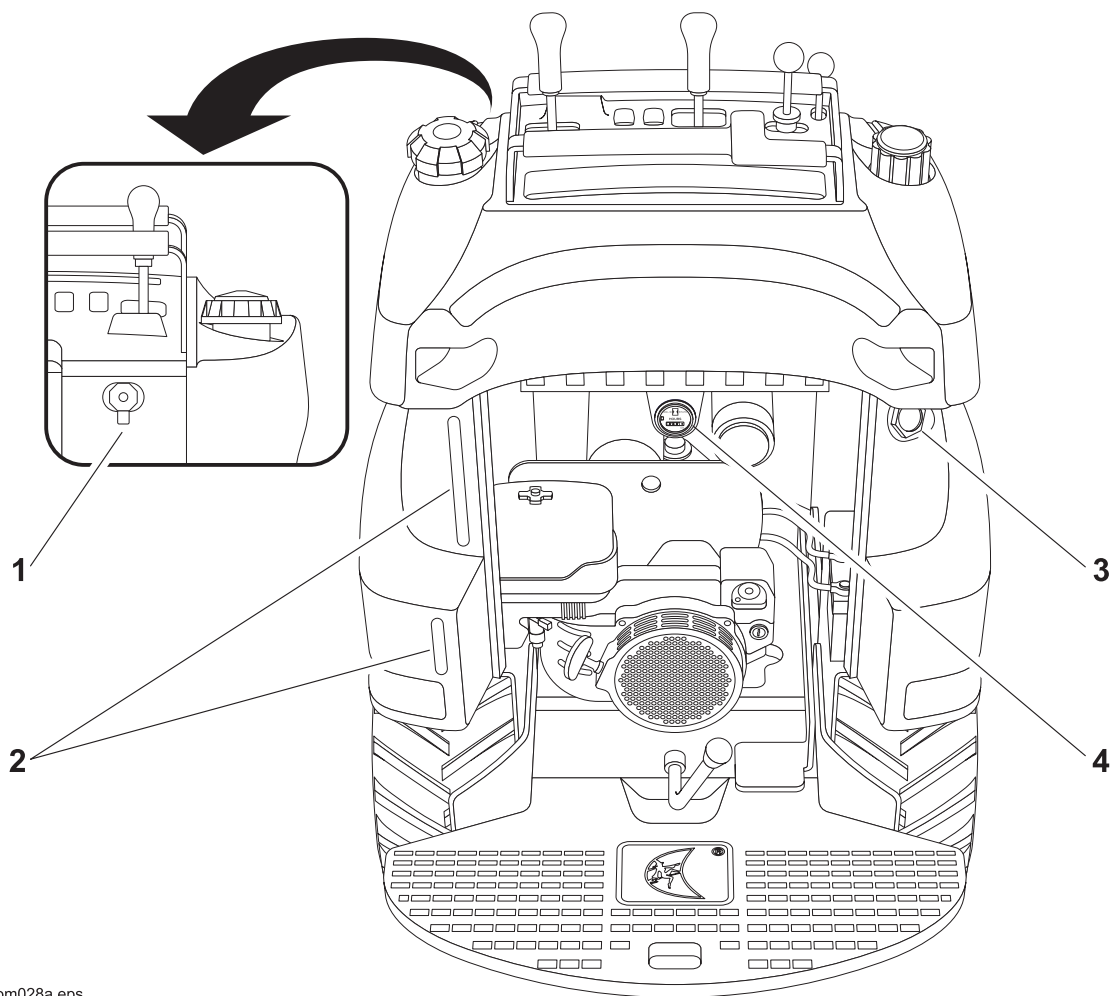

t22om028a.eps

- 1. Auxiliary power outlet (R150E/R230/R300 only)
- 2. Fuel sight glass
- 3. Hydraulic fluid sight glass
- 4. Hourmeter (optional)

Item	Description	Notes
1. Auxiliary power outlet	To operate work lights or other 12V devices, plug into outlet.	Not available on R150 with rope start.
2. Fuel tank sight window	Shows level of fuel in tank.	
3. Hydraulic fluid sight glass	Shows level of hydraulic fluid in tank. Maintain fluid at halfway point on glass.	

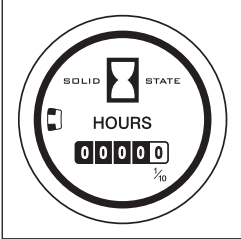
Item	Description	Notes
<p>4. Hourmeter (optional)</p>  <p>c00ic019h.eps</p>	<p>Displays engine operating time.</p>	<p>Use these times to schedule service.</p>



Controls

R150/R150E

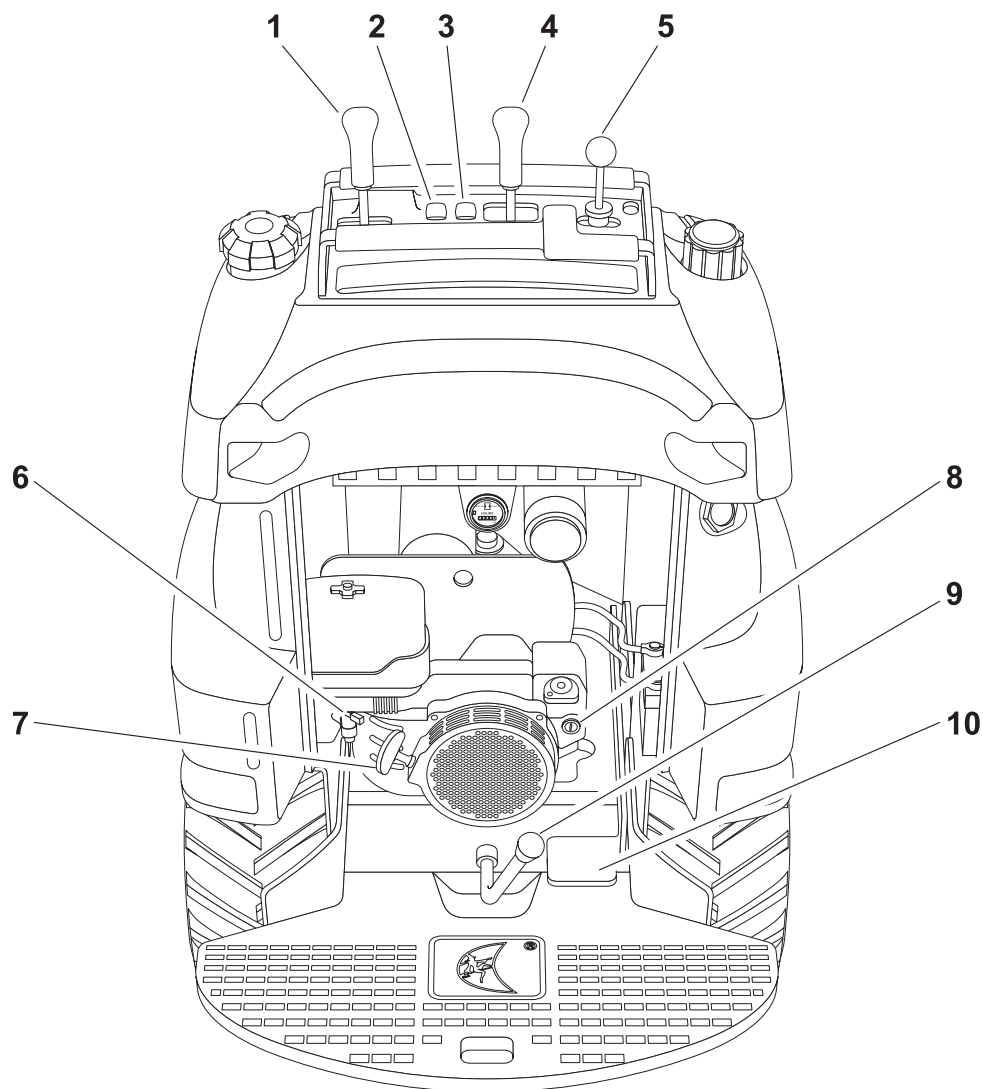

t22om030a.eps

1. Ground drive control
2. Traction assist switch
3. Throttle switch
4. Front end lift control
5. Front end drive control
6. Choke (R150)/manual start switch (R150E)
7. Rope start
8. Ignition switch
9. Parking brake
10. Cruise control pedal

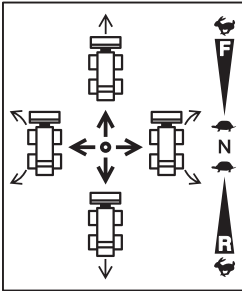
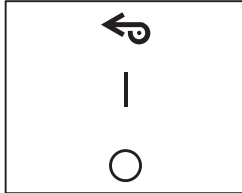
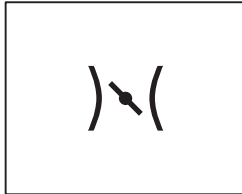
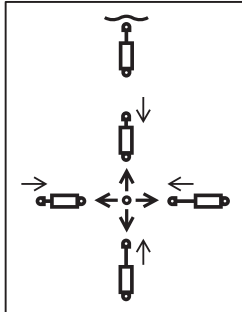
Item	Description	Notes
<p>1. Ground drive control</p>  <p>c00ic128a.eps</p>	<p>To move forward, push.</p> <p>To move backward, pull.</p> <p>To turn right, move to right.</p> <p>To turn left, move to left.</p> <p>To go faster in any direction, move control farther from neutral position.</p> <p>To stop, release.</p>	<p>To make a gradual turn, move control halfway between desired directions and return to center. Unit will remain articulated until it is returned to center.</p> <p>IMPORTANT: As long as control is moved to right or left, unit is articulating and turning is tightened.</p>
<p>2. Traction assist switch</p>  <p>c00ic129a.eps</p>	<p>To allow maximum power to tires, press top.</p> <p>To return to normal operation, press bottom.</p>	<p>Use when working on a slope to lessen undesired movement.</p>
<p>3. Throttle switch</p>  <p>c00ic130a.eps</p>	<p>To set engine speed for operation, press top.</p> <p>To set speed to middle range for transport, move to center position</p> <p>To decrease speed to idle, press bottom.</p>	
<p>4. Front end lift control</p>  <p>c00ic131a.eps</p>	<p>To lower trencher, push.</p> <p>To raise trencher, pull.</p>	

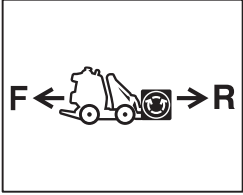
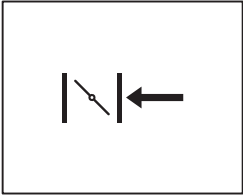
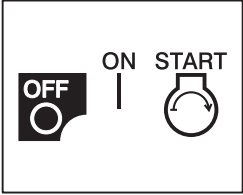

Item	Description	Notes
<p>5. Front end drive control</p>  <p>c00ic132a.eps</p>	<p>To engage front end drive in reverse, lift lever release and move to right.</p> <p>To engage front end drive in forward, lift lever release and move to left.</p>	
<p>6. Choke/manual start switch</p>  <p>c00ic134a.eps</p>	<p>Choke (R150)</p> <p>To help start cold engine, close valve.</p> <p>Manual start switch (R150E)</p> <p>To manually start engine when electric starter doesn't work, move switch to right, turn on power switch and pull rope start.</p>	<p>This valve regulates air/fuel mixture.</p> <p>IMPORTANT: R150E units have automatic choke feature.</p>
<p>7. Rope start</p>	<p>To start engine, pull rope.</p>	<p>Ignition switch must be on for this control to function.</p> <p>If engine does not start after three pulls, turn power switch off and check for fuel blockage or electrical system problems.</p>
<p>8. Ignition switch</p>  <p>c00ic137a.eps</p>	<p>R150</p> <p>To start engine, insert key and turn clockwise. Pull rope start.</p> <p>To stop engine, turn key counterclockwise.</p> <p>R150E</p> <p>To start engine, insert key and turn clockwise.</p> <p>To stop engine, turn key counterclockwise.</p>	<p>IMPORTANT:</p> <ul style="list-style-type: none"> If engine does not start, turn key to OFF and then restart. Do not allow starter motor to run continuously for more than 20 seconds.

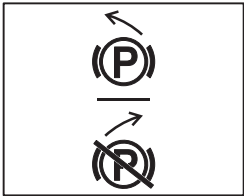
Item	Description	Notes
<p>9. Parking brake lever</p>  <p>c00ic139a.eps</p>	<p>To engage, move handle to left.</p> <p>To disengage, move handle to right.</p>	<p>IMPORTANT:</p> <ul style="list-style-type: none"> • Move unit slightly to ensure parking brake pins are engaged. • It might be necessary to move unit slightly to disengage parking brake.
<p>10. Cruise control pedal</p>	<p>To maintain ground drive and front end drive settings, press pedal and release handles.</p> <p>To adjust settings, grab drive handles, step off pedal, adjust drive settings, press pedal and release handles.</p>	<p>NOTICE: Pedal must return to neutral when released. Never tie down or use anything other than foot to hold pedal down.</p>



R230/R300

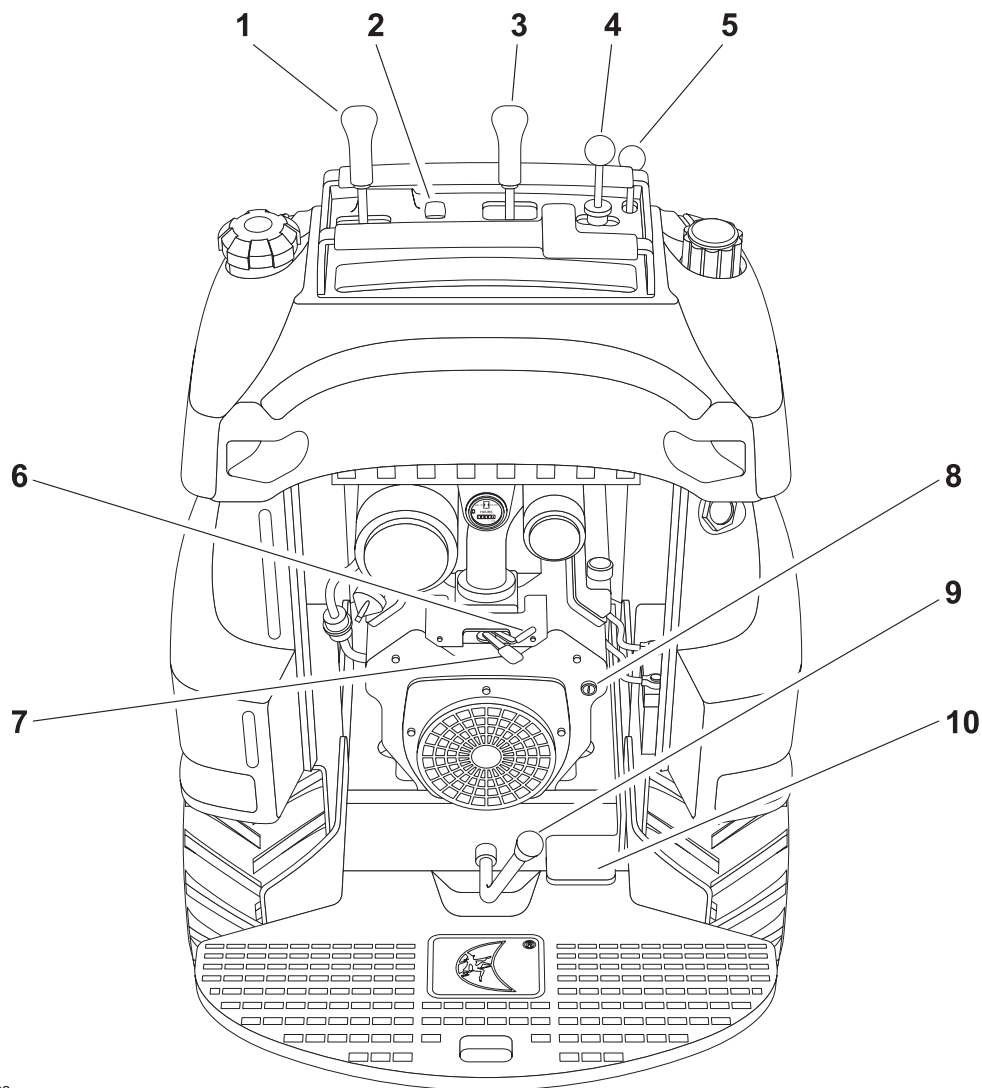

t22om031a.eps

- | | |
|---------------------------------------|--------------------------|
| 1. Ground drive control | 6. Choke |
| 2. Traction assist switch | 7. Throttle |
| 3. Front end lift control | 8. Ignition switch |
| 4. Front end drive control | 9. Parking brake |
| 5. Remote throttle control (optional) | 10. Cruise control pedal |

Item	Description	Notes
<p>1. Ground drive control</p> <p>c00ic128a.eps</p>	<p>To move forward, push.</p> <p>To move backward, pull.</p> <p>To turn right, move to right.</p> <p>To turn left, move to left.</p> <p>To go faster in any direction, move control farther from neutral position.</p> <p>To stop, release.</p>	<p>To make a gradual turn, move control halfway between desired directions and return to center. Unit will remain articulated until it is returned to center.</p> <p>IMPORTANT: As long as control is moved to right or left, unit is articulating and turning is tightened.</p>
<p>2. Traction assist switch</p> <p>c00ic129a.eps</p>	<p>To allow maximum power to tires, press top.</p> <p>To return to normal operation, press bottom.</p>	<p>Use when working on a slope to lessen undesired track movement.</p>
<p>3. Front end lift control</p> <p>c00ic131a.eps</p>	<p>To retract primary cylinder or lower trencher, push.</p> <p>To float, push forward to detent.</p> <p>To extend primary cylinder or raise trencher, pull.</p> <p>To retract secondary cylinder, move to left.</p> <p>To extend secondary cylinder, move to right.</p>	<p>IMPORTANT: Front end will drop when unit is put in float position.</p>
<p>4. Front end drive control</p> <p>c00ic132a.eps</p>	<p>To engage front end drive in reverse, lift lever release and move to right.</p> <p>To engage front end drive in forward, lift lever release and move to left.</p>	

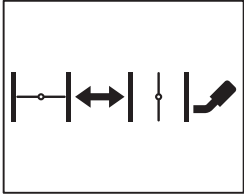
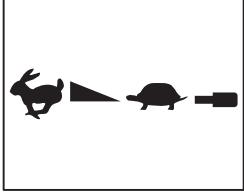
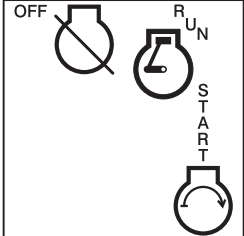
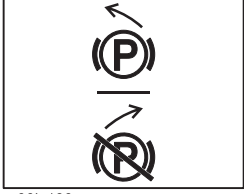

Item	Description	Notes
<p>5. Remote throttle control (optional)</p>  <p>c00ic133a.eps</p>	<p>To increase engine speed, push.</p> <p>To decrease engine speed, pull.</p>	<p>NOTICE: R300 units must be stopped at full throttle to prevent backfiring.</p>
<p>6. Choke</p>  <p>c00ic135a.eps</p>	<p>To help start cold engine, move to left.</p> <p>Move to right after engine has warmed.</p>	<p>This valve regulates air/fuel mixture.</p>
<p>7. Throttle</p>  <p>c00ic136a.eps</p>	<p>To increase engine speed, move to left.</p> <p>To decrease engine speed, move to right.</p>	<p>This throttle is disengaged if remote throttle is installed.</p> <p>NOTICE: R300 units must be stopped at full throttle to prevent backfiring.</p>
<p>8. Ignition switch</p>  <p>c00ic138a.eps</p>	<p>To start engine, insert key and turn clockwise.</p> <p>To stop engine, turn key counterclockwise.</p>	<p>NOTICE: R300 units must be stopped at full throttle to prevent backfiring.</p> <p>IMPORTANT:</p> <ul style="list-style-type: none"> • If engine does not start, turn key to OFF and then restart. • Do not allow starter motor to run continuously for more than 20 seconds.
<p>9. Parking brake lever</p>  <p>c00ic139a.eps</p>	<p>To engage, move handle to left.</p> <p>To disengage, move handle to right.</p>	<p>IMPORTANT:</p> <ul style="list-style-type: none"> • Move unit slightly to ensure parking brake pins are engaged. • It might be necessary to move unit slightly to disengage parking brake.

Item	Description	Notes
10. Cruise control pedal	To maintain ground drive and front end drive settings, press pedal and release handles. To adjust settings, grab drive handles, step off pedal, adjust drive settings, press pedal and release handles.	NOTICE: Pedal must return to neutral when released. Never tie down or use anything other than foot to hold pedal down.



R150/R230/R300

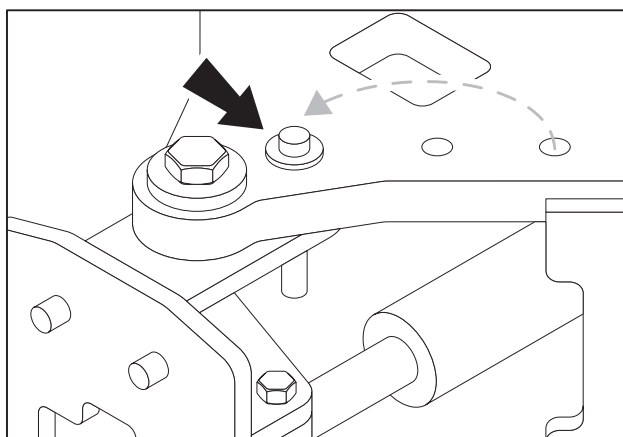

t22om032a.eps

1. Articulation lock

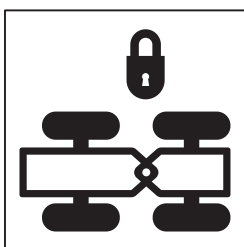

c00ic140a.eps

To lock articulation joint, align top and bottom holes and put pin in hole (shown).

To unlock articulation joint, return pin to storage hole.

Lock for transporting and lifting.

Unlock to maneuver unit.

Prepare

Chapter Contents

Gather Information 34

Inspect Site 35

- Identify Hazards 35

Classify Jobsite 36

- Inspect Jobsite 36
- Select a Classification 36
- Apply Precautions 37

Check Supplies and Prepare Equipment 38

- Supplies 38
- Fluid Levels 38
- Condition and Function 38
- Accessories 38

Attach Front End to InterChange Connection . . . 38



Gather Information

A successful job begins before you start working. The first step in planning is reviewing information already available about the job and jobsite.

Review Job Plan

Review blueprints or other plans. Check for information about existing or planned structures, elevations, or proposed work that may be taking place at the same time.

Arrange for Traffic Control

If working near a road or other traffic area, contact local authorities about safety procedures and regulations.

Plan for Emergency Services

Have the telephone numbers for local emergency and medical facilities on hand. Check that you will have access to a telephone.

Notify One-Call Services

Contact your local One-Call (811 in USA) or the One-Call referral number (888-258-0808 in USA and Canada) to have underground utilities located before digging. Also contact any utilities that do not participate in the One-Call service.

Inspect Site

Inspect jobsite before transporting equipment. Check for the following:

- changes in elevation such as hills or other open trenches
- obstacles such as buildings, railroad crossings, or streams
- signs of utilities (See "Inspect Jobsite" on page 36.)
- traffic
- access
- soil type and condition

Identify Hazards

Identify safety hazards and classify jobsite if front end or attachment will penetrate ground. See "Classify Jobsite" on page 36.



⚠ WARNING

Jobsite hazards could cause death or serious injury. Use correct equipment and work methods. Use and maintain proper safety equipment.

NOTICE:

- Wear personal protective equipment including hard hat, safety eye wear, and hearing protection.
- Do not wear jewelry or loose clothing.
- Notify One-Call and companies which do not subscribe to One-Call.
- Comply with all utility notification regulations before digging or drilling.
- Verify location of previously marked underground hazards.
- Mark jobsite clearly and keep spectators away.

Remember, jobsite is classified by hazards in place -- not by line being installed.

Classify Jobsite

Inspect Jobsite

- Inspect jobsite and perimeter for evidence of underground hazards, such as:
 - “buried utility” notices
 - utility facilities without overhead lines
 - gas or water meters
 - junction boxes
 - drop boxes
 - light poles
 - manhole covers
 - sunken ground
- Follow U.S. Department of Labor regulations on excavating and trenching (Part 1926, Subpart P) and other similar regulations.
- Contact your local One-Call (811 in USA) or the One-Call referral number (888-258-0808 in USA and Canada) to have underground utilities located before digging. Also contact any utilities that do not participate in the One-Call service.
- Have an experienced locating equipment operator sweep area within 20' (6 m) to each side of work path. Verify previously marked line and cable locations.
- Mark location of all buried utilities and obstructions.
- Classify jobsite.

Select a Classification

Jobsites are classified according to underground hazards present.

If working . . .	then classify jobsite as . . .
within 10' (3 m) of a buried electric line	electric
within 10' (3 m) of a natural gas line	natural gas
in sand or granite which is capable of producing crystalline silica (quartz) dust	crystalline silica (quartz) dust
within 10' (3 m) of any other hazard	other

NOTICE: If you have any doubt about jobsite classification, or if jobsite might contain unmarked hazards, take steps outlined previously to identify hazards and classify jobsite before working.

Apply Precautions

Once classified, precautions appropriate for jobsite must be taken.

Electric Jobsite Precautions

Use one or both of these methods.

- Expose line by careful hand digging or soft excavation.
- Have service shut down while work is in progress. Have electric company test lines before returning them to service.

Natural Gas Jobsite Precautions

In addition to positioning equipment upwind from gas lines, use one or both of these methods.

- Expose lines by careful hand digging or soft excavation.
- Have gas shut off while work is in progress. Have gas company test lines before returning them to service.



Crystalline Silica (Quartz) Dust Precautions

Follow OSHA or other guidelines for exposure to crystalline silica when trenching, sawing or drilling through material that might produce dust containing crystalline silica (quartz).

Other Jobsite Precautions

You may need to use different methods to safely avoid other underground hazards. Talk with those knowledgeable about hazards present at each site to determine which precautions should be taken or if job should be attempted.

Check Supplies and Prepare Equipment

Supplies

- fuel
- lubricants

Fluid Levels

- fuel
- hydraulic fluid
- battery charge
- engine oil

Condition and Function

- parking brake pins (see "Check Parking Brake Operation" on page 65)
- filters (air, oil, hydraulic)
- pumps and motors
- hoses and valves
- signs, guards, and shields

Accessories

Fire Extinguisher

Mount a fire extinguisher near the power unit but away from possible points of ignition. The fire extinguisher should always be classified for both oil and electric fires. It should meet legal and regulatory requirements.

Attach Front End to InterChange Connection

Precautions

IMPORTANT: Use only Ditch Witch-approved front ends and attachments. Other front ends and attachments will change the stability and operating characteristics of the unit.

See front end operation sheet for instructions for connecting/disconnecting front ends.

Drive

Chapter Contents

Start Unit	40
Drive	41
Shut Down	42



Start Unit

EMERGENCY SHUTDOWN: Release all controls (including cruise control pedal) and turn ignition switch to OFF.

R150

1. Ensure all controls are in neutral and parking brake is engaged.
2. Turn key to on position.
3. Move throttle switch to center position.
4. Choke engine, if necessary.
5. Pull rope or turn ignition switch to start position and release when engine starts.

R230/R300

1. Ensure all controls are in neutral and parking brake is engaged.
2. Move throttle to half open.
3. Choke engine, if necessary.
4. Turn ignition switch to start position and release when engine starts. See "Ignition switch" on page 30.

Drive



⚠ WARNING

Incorrect procedures could result in death, injury, or property damage. Learn to use equipment correctly.

NOTICE: Operate unit only while standing on platform.

General Operation



⚠ WARNING

Tipover possible. Machine can tip over and crush you.

- Always operate with load end uphill.
- Always carry load low. High load can cause tipping, loss of load or loss of visibility.
- Never jerk control levers. Use a steady even motion.



1. Disengage parking brake.
2. Pull front end lift control to raise front end off ground.
3. Move ground drive control to forward or reverse.
4. Adjust throttle as needed.
5. Move ground drive control to side to steer in that direction.

IMPORTANT: For continuous ground drive and front end drive operation, use cruise control pedal. See "Cruise control pedal" on page 27.

Slope Operation Guidelines

- Engage traction control when working on a slope to lessen undesired movement.
- Keep heavy end of unit uphill on slopes.
- Avoid starting, stopping, or turning on slopes. If you must turn, keep the heavy end of the unit uphill.
- Avoid parking unit on a slope. If parking on a slope cannot be avoided, lower front end, engage parking brake and turn ignition switch to OFF.

Shut Down

1. Lower front end to ground.
2. Move all controls to neutral position.
3. Engage parking brake.
4. Move throttle to center position (R150) or to full open (R230/R300).
5. Turn ignition switch to OFF.
6. Remove key.

Transport

Chapter Contents

Lift **44**

- Points44
- Procedure45

Haul **46**

- Load46
- Tie Down47
- Unload48

Tow **49**



Lift



WARNING Crushing weight. If load falls or moves it could kill or crush you. Use proper procedures and equipment or stay away.

Points

Lifting points are identified by lifting decals. Lifting at other points is unsafe and can damage machinery.

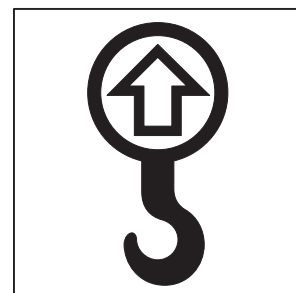

ic1319a.eps

Procedure

Use a hoist capable of supporting the equipment's size and weight. See "Specifications" on page 81 or measure and weigh equipment before lifting.

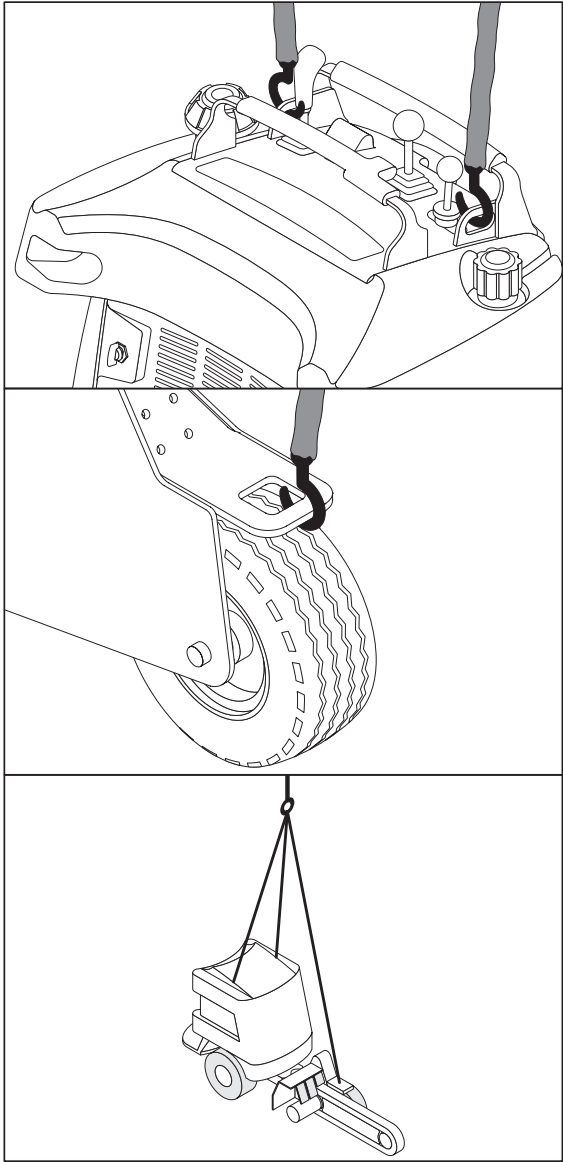
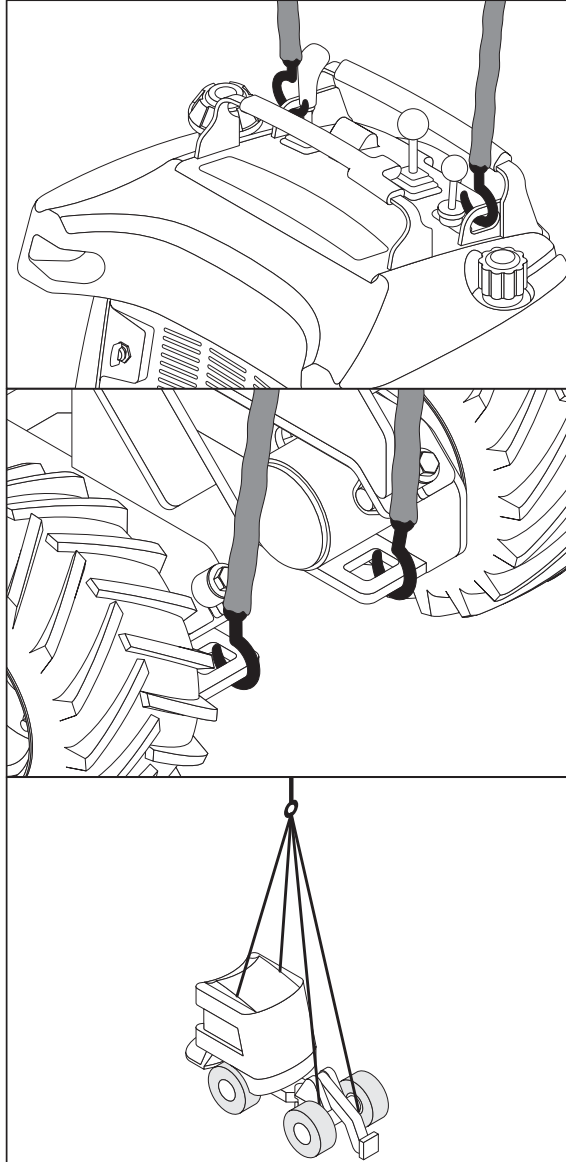
Configured trencher	Configured 4-wheel drive unit only
Lock articulation joint and use three lift points as shown.	Lock articulation joint and use four lift points as shown.
 <p>t22om067a.eps</p>	 <p>t22om065a.eps</p>



To lift configured 4-wheel drive unit with front end, see appropriate front end operation sheet.

Haul

IMPORTANT: For trailer information, see the trailer manufacturer's manual.

Load



WARNING Crushing weight. If load falls or moves it could kill or crush you. Use proper procedures and equipment or stay away.



WARNING Tipover possible. Machine can tip over and crush you.

- Always operate with heavy end uphill.
- Lock articulation joint when transporting.

IMPORTANT: Do not remove front end from InterChange connection before loading or unloading power unit.

1. Disengage parking brake.
2. Start engine and slow to low throttle.
3. Pull front end lift control to raise front end clear of trailer, but keep it low.
4. Move unit to rear of trailer and align with ramps.
5. Move ground drive control forward and slowly move unit onto trailer until tiedown position is reached.

NOTICE:

- If loading onto tilt-bed trailer, be prepared for trailer bed to tilt.
- Move all controls to neutral position when stopped.

6. Push front end lift control to lower front end to trailer bed.
7. Engage parking brake and turn ignition switch to OFF.
8. Lock articulation joint.
9. Close fuel tank shutoff valve (shown).
10. Tie down unit.

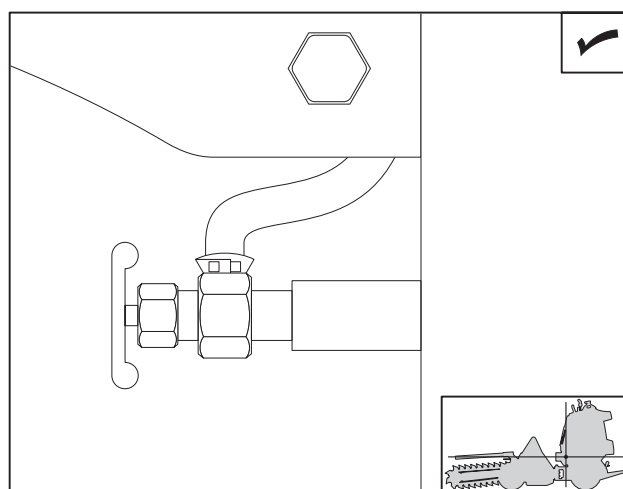

t22om090a.eps

Tie Down

Points

Tiedown points are identified by tiedown decals. Securing to truck or trailer at other points is unsafe and can damage machinery.

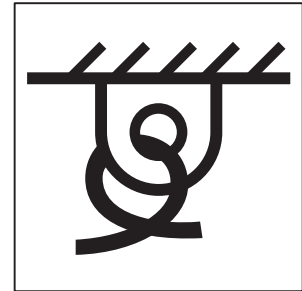

ic1320a.eps

Procedure

Configured Trencher

Loop tiedowns around unit at tiedown points. Make sure tiedowns are tight before transporting.

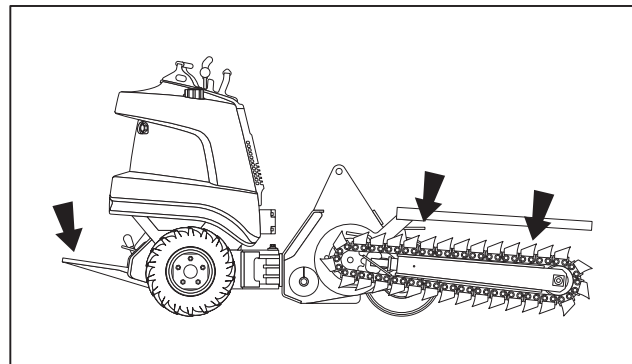

t22om076a.eps



Other Front Ends

To tie down unit with any other front end, see appropriate front end operation sheet.

IMPORTANT:

- Do not remove front end from InterChange connection before loading or unloading unit.
- Use a crane or hoist if loading additional front ends onto trailer.

Unload



WARNING Crushing weight. If load falls or moves it could kill or crush you. Use proper procedures and equipment or stay away.



WARNING Tipover possible. Machine can tip over and crush you. Always operate with heavy end uphill.

IMPORTANT: Do not remove front end from InterChange connection before loading or unloading power unit.

1. Lower trailer or ramps and remove tiedowns.
2. Unlock articulation joint.
3. Open fuel tank shutoff valve.
4. Start engine and disengage parking brake.
5. Pull front end lift control to raise front end, but keep it low.
6. Slow engine to low throttle and slowly back unit down trailer or ramps.

NOTICE: If unloading from tilt-bed trailer, be prepared for trailer bed to tilt.

Tow

Under normal conditions, unit should not be towed. If unit breaks down and towing is necessary:

- attach chains to tow point (shown) facing towing vehicle
 - tow for short distances at less than 1 mph (1.6 km/h)
 - do not tow for more than 100' (30 m)
 - use no more than 1,300 lb (5800 N) of towing force
-
- disengage parking brake as shown

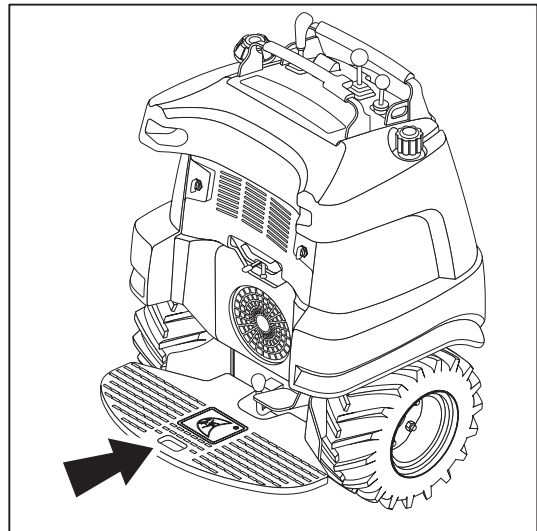

t22om036a.eps

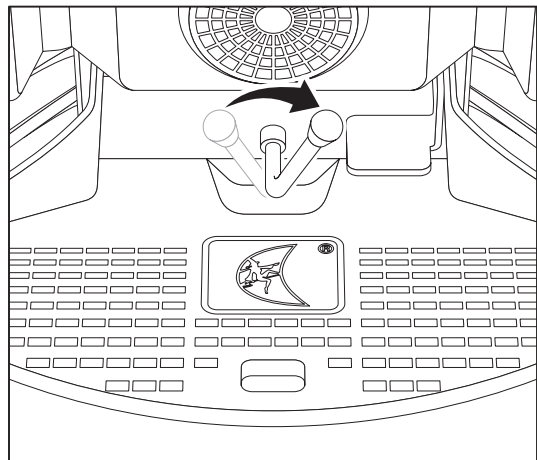

t22om037a.eps



Prepare Unit for Towing

1. Ensure parking brake is engaged.
2. Block wheels.
3. Connect to tow point.
4. Turn tow valve (shown).
 - R150 (top illustration): Turn counterclockwise two turns.
 - R230/R300 (bottom illustration): Turn counterclockwise 1/4 turn.
5. Disengage parking brake. See "Parking brake lever" on page 27.
6. Unblock wheels.

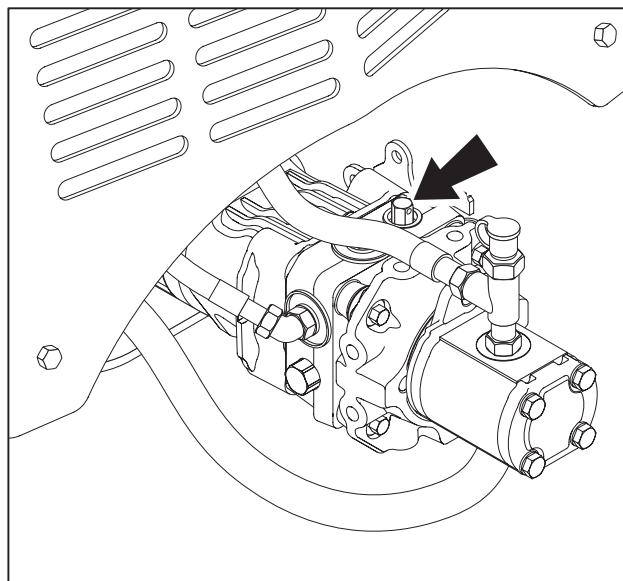

t22om038a.eps

Return Unit to Normal Operation

1. Engage parking brake.
2. Block wheels.
3. Disconnect from tow point.
4. Turn tow valve.
 - R150 (top illustration): Turn clockwise two turns.
 - R230/R300 (bottom illustration): Turn clockwise 1/4 turn.
5. Unblock wheels.
6. Disengage parking brake. See "Parking brake lever" on page 27.

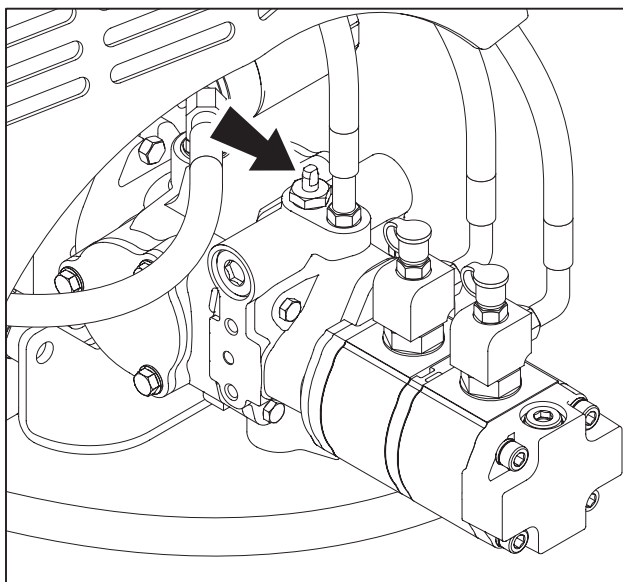

t22om039a.eps

Trench

Chapter Contents

Trench 53



**⚠ DANGER**

Electrical shock. Contacting electrical lines will cause death or serious injury. Know location of lines and stay away.

NOTICE: Cutting high voltage cable can cause electrocution. Expose lines by hand before digging.

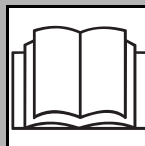
**⚠ WARNING**

Incorrect procedures could result in death, injury, or property damage. Learn to use equipment correctly.

NOTICE:

- Comply with all utility notification regulations before digging or drilling.
- Notify companies that do not subscribe to One-Call.

**⚠ CAUTION**

Flying objects thrown by machine may strike people. Wear hard hat and safety glasses.

Trench



Moving digging teeth will cause death or serious injury. Stay away.

NOTICE:

- Keep everyone at least 6' (2 m) from machine, digging boom, and its range of movement.
- Machine may move when chain starts to dig. Allow 3' (1 m) between end of chain and obstacle.
- Operate unit only while standing on platform.

1. Move unit to starting point of trench.

IMPORTANT:

- When beginning trench near a wall or fence, allow enough distance between boom and footings, drains, and cables.
- When cutting across asphalt roads, start trench in soil at edge of road and dig with boom at full digging depth.
- When straight trenching across a slope, it can be helpful to stake a wooden beam parallel to intended course and just far enough from trench to guide downslope wheels.

2. Engage parking brake and move throttle to half open.
3. Use front end lift control to lower trencher to 1" (25 mm) above ground surface.
4. Use front end drive control to start forward digging chain rotation. DIGGING CHAIN WILL MOVE.
5. Increase engine speed to full throttle.
6. Use front end lift control to slowly lower digging boom to digging depth.



7. Disengage parking brake and pull ground drive control to begin trenching. UNIT WILL MOVE.

IMPORTANT:

- Trenching movement is toward you.
- For easier turning, lower boom to full depth.
- If an object becomes lodged in chain, move digging chain control to neutral and raise boom slightly. Reverse chain direction. If object must be removed manually, stop engine.

8. For continuous ground drive and front end drive operation, use cruise control pedal. See "Cruise control pedal" on page 27.
9. When trench is complete, move ground drive control to neutral.
10. Move throttle to half open.
11. Use front end lift control to raise boom to top of trench.
12. Use front end drive control to stop digging chain rotation.
13. Use front end lift control to raise trencher.
14. Use ground drive control to drive unit away from trench.
15. Lower trencher to ground surface.
16. Stop engine.

Systems and Equipment



Chapter Contents

Chain, Teeth, and Sprockets	56
• Chain and Tooth Maintenance56
• Chain Types56
• Chain Selection57
Optional Equipment	58

Chain, Teeth, and Sprockets

Chain and Tooth Maintenance

- Always replace sprockets at the same time you replace the digging chain. Sprockets and chain are designed to work together. Replacing one without the other will cause premature wear of the new part.
- Keep digging teeth sharp. Using dull, worn teeth will decrease production and increase shock load to other trencher components. It can also cause chain stretch, which leads to premature chain wear and failure.
- Maintain the proper amount of tension on the digging chain. Overtightening will cause chain stretch and loss of machine performance. For correct tightening procedure, see page 67.
- Use the tooth pattern most appropriate for your digging conditions. If you move to a different soil type, contact your Ditch Witch dealer for information about the most effective chain type and tooth pattern.

Chain Types

Chain type	Features
4-pitch	standard chain
2-pitch	more teeth for smoother cutting
alternating side bar	prevents spoil compaction on chain
bolt-on adapters	allow easy configuration changes
Shark Chain II	versatile, virtually maintenance-free
combination	provides pick and shovel effect

Chain Selection



These charts are meant as a guideline only. No one chain type works well in all conditions. See your Ditch Witch dealer for soil conditions and chain recommendations for your area. Ask for the latest Chain, Teeth, and Sprockets Parts Catalog.

- 1 = best
- 2 = better
- 3 = good
- 4 = not recommended

Chain	Sandy Soil	Soft Soil	Medium Soil	Hard Soil	Rocky Soil	Sticky Soil
4-pitch cup tooth	3	1	2	3	4	1
2-pitch cup tooth	2	3	1	1	3	4
bolt-on adaptor, 2-pitch	4	4	3	2	1	4
bolt-on adaptor/cup tooth combo	4	3	2	1	2	4
Shark Chain II	4	3	2	1	1	4
alternating side bar	4	4	4	4	4	1

Soil	Description
sandy soil	sugar sand, blow sand, or other soils where sand is the predominant component
soft soil	sandy loam
medium soil	loams, loamy clays
hard soil	packed clays, gumbo, all compacted soils
rocky soil	chunk rock, glacial till, cobble, rip rap, gravel
sticky soil	gumbo, sticky clays

Optional Equipment

See your Ditch Witch dealer for information about available optional equipment.

Complete the Job

Chapter Contents

Restore Jobsite 60

- Backfilling 60

Rinse Equipment 60

Stow Tools 60



Restore Jobsite

After product is installed, return spoils to the trench with optional backfill blade.

Backfilling

1. Turn off engine.
2. Install backfill blade and secure with pull pins, as shown.
3. Start unit.
4. Position unit at end of trench, several feet from spoils. Aim unit at outer edge of spoils.
5. Adjust backfill blade to fit land contour.
6. Move outer edge of spoils toward trench. Take two or more passes at spoils rather than moving all spoils at once.
7. Repeat on other side of trench, if necessary.
- 8.

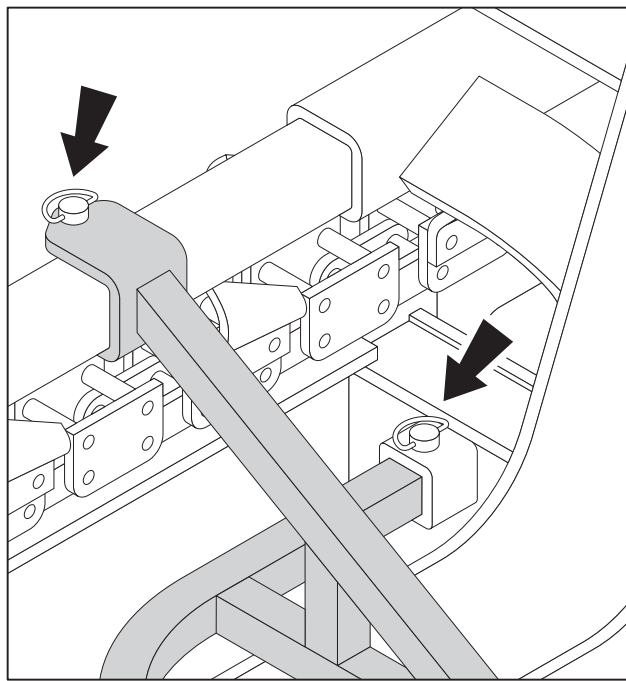

t22om053a.eps

Rinse Equipment

Spray water onto equipment to remove dirt and mud.

NOTICE: Do not spray water onto operator's console. Electrical components could be damaged. Wipe down instead.

Stow Tools

Make sure all tools and accessories are loaded and secured on trailer.

Service

Chapter Contents

Service Precautions 62

Recommended Lubricants/Service Key 62

Oil Temperature Chart 63

Each Use 64

10 Hour 66

20 Hour 69

50 Hour 71

100 Hour 73

250 Hour 75

500 Hour 77

As Needed 78



Service Precautions

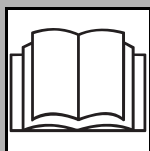







WARNING Incorrect procedures could result in death, injury, or property damage. Learn to use equipment correctly.

NOTICES:

- Unless otherwise instructed, all service should be performed with engine off.
- Refer to engine manufacturer's manual for engine maintenance instructions.
- Before servicing equipment, lower unstowed front ends to ground.

Recommended Lubricants/Service Key

Item	Description
 GEO	Gasoline engine oil meeting current API service classifications and SAE viscosity recommended by engine manufacturer (SAE 10W30)
 MPG	Multipurpose grease meeting ASTM D217 and NLGI 3
 THF	Tractor hydraulic fluid, similar to Phillips 66 HG, Mobilfluid 423, Chevron Tractor Hydraulic Fluid, Texaco TDH Oil, or equivalent
	Check level of fluid or lubricant
	Check condition
	Filter
	Change, replace, adjust, service or test

Proper lubrication and maintenance protects Ditch Witch equipment from damage and failure. Service intervals listed are for minimum requirements. In extreme conditions, service machine more frequently. Use only recommended lubricants. Fill to capacities listed in "Specifications" on page 81.

NOTICE:

- Use only genuine Ditch Witch parts, filters, and approved lubricants to maintain warranty.
- Use the "Service Record" on page 103 to record all required service to your machine.

Engine Oil Temperature Chart

R150

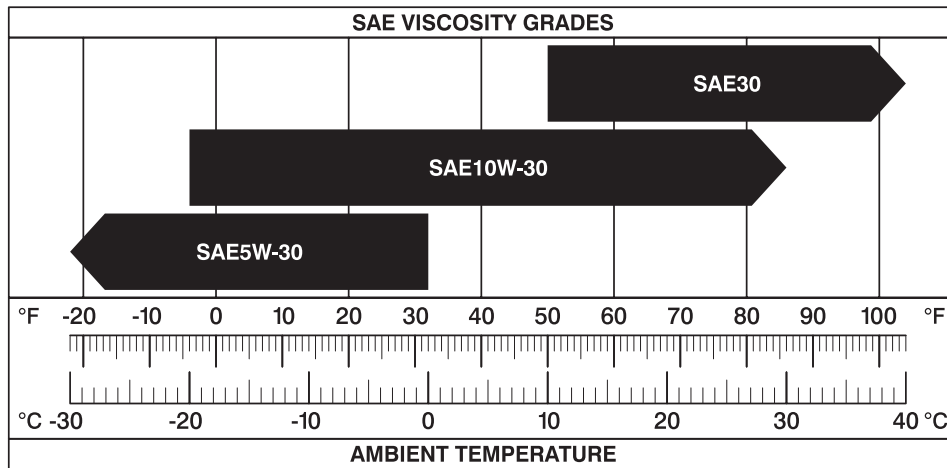

t22om054a.eps

Temperature range anticipated before next oil change

R230/R300

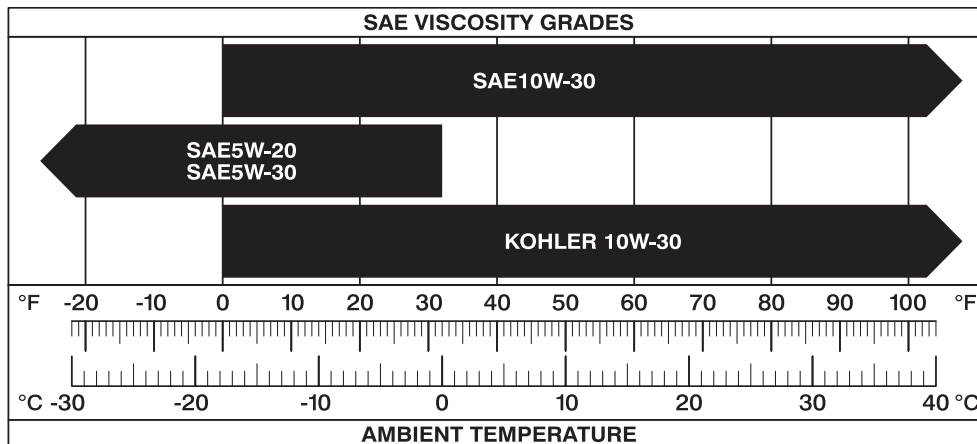

t22om055a.eps

Temperature range anticipated before next oil change

For more information on engine lubrication and maintenance, see your engine manual.



Each Use

Location	Task	Notes
Power Unit	Check engine oil level	GEO
	Check hydraulic fluid level	THF
	Check parking brake operation	
	Check tires	Bar lug tire: 12 psi (82.7 kPa) Turf tire: 22 psi (151 kPa) Lug nut torque: 65-70 ft•lb (88-95 N•m)

Power Unit

Check Engine Oil Level - R150

Check engine oil at dipstick (1) before each use. If low, add GEO until oil level is at highest line on dipstick.

IMPORTANT: For more information on engine oil, see "Recommended Lubricants/Service Key" on page 62 or see engine manual.

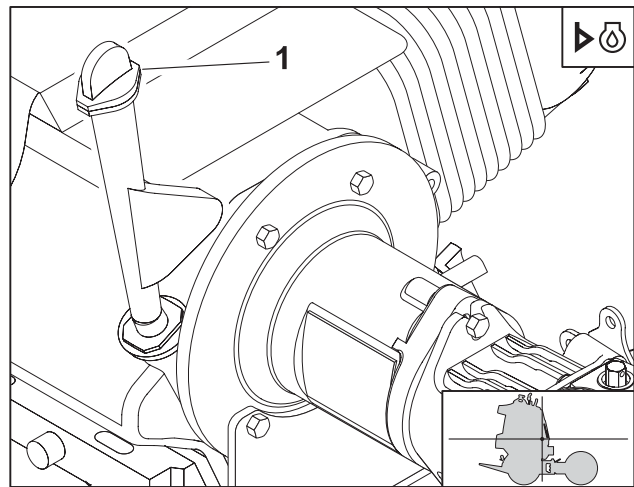

t22om040a.eps

Check Engine Oil Level - R230/R300

Check engine oil at dipstick (1) before each use. If low, add GEO until oil level is at highest line on dipstick.

IMPORTANT: For more information on engine oil, see "Recommended Lubricants/Service Key" on page 62 or see engine manual.

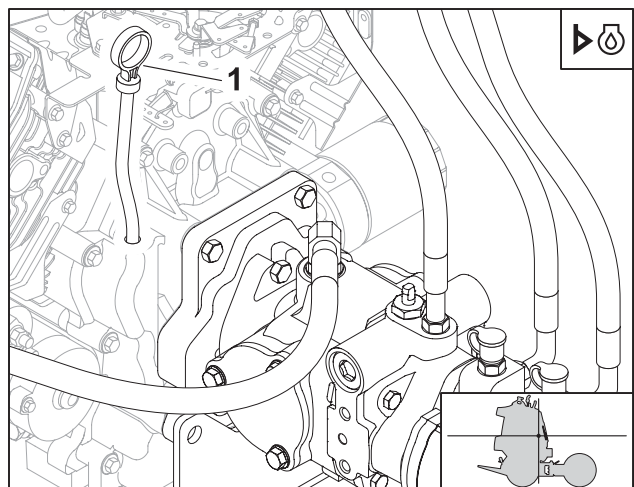

t22om041a.eps

Check Hydraulic Fluid Level

With digging boom fully raised, check hydraulic fluid level at sight glass (2) before each use. If low, add THF until level is at halfway point on sight glass. Clean dust from cap (1) by blowing with low pressure air.

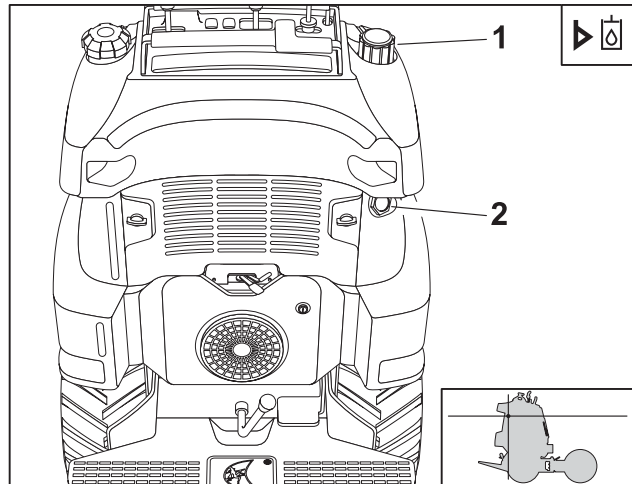

t22om042a.eps

Check Parking Brake Operation

Verify that parking brake pins engage as shown before each use.

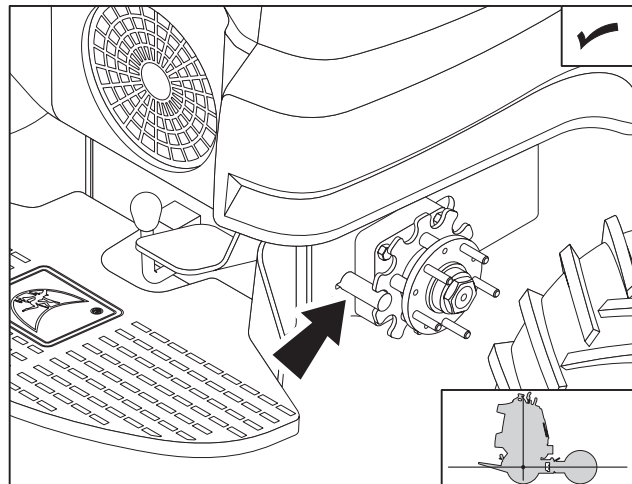

t22om043a.eps

Check Tires

Check power unit tire pressure (2, if necessary) before each use. Maintain pressure as indicated below.

- Bar lug tire: 12 psi (82.7 kPa).
- Turf tire: 22 psi (151 kPa).

Check lug nut (1) tightness before each use. Tighten to 65-70 ft•lb (88-95 N•m).

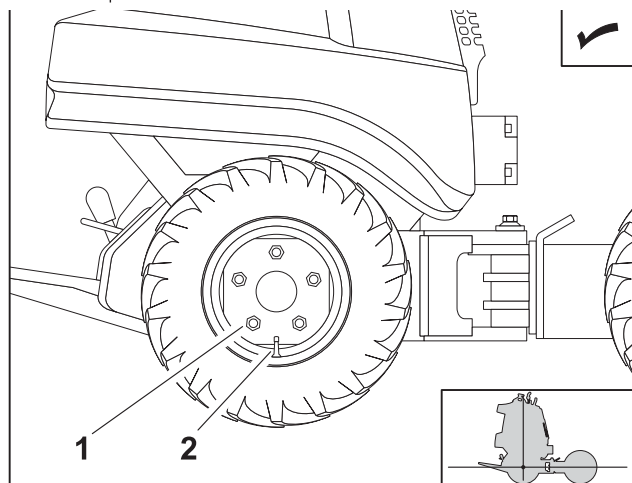

t22om056a.eps



10 Hour

Location	Task	Notes
Power Unit	Check hydraulic hoses	
	Inspect insulation	R150 only
Trencher	Lube trencher pivot	MPG
	Lube trencher headshaft bearing	MPG
	Check digging chain tension	MPG

Power Unit

Check Hydraulic Hoses

Check hydraulic hoses for leaks every 10 hours.

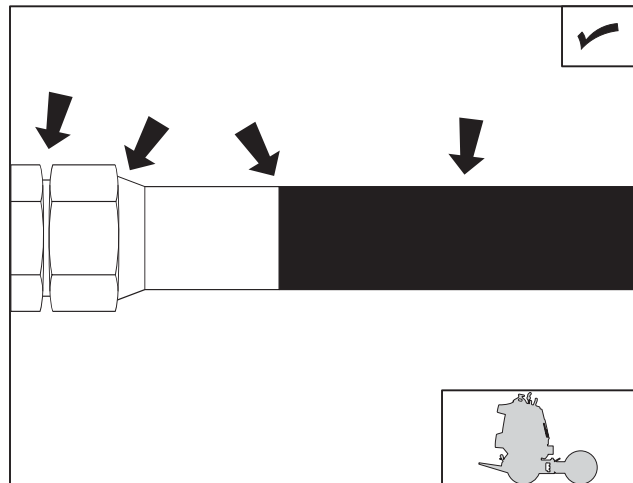

t22om044a.eps

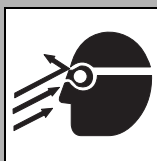

WARNING Fluid or air pressure could pierce skin and cause injury or death. Stay away.

NOTICE: Escaping pressurized fluid can cause injury or pierce skin and poison.

- Before disconnecting a hydraulic line, turn engine off and operate all controls to relieve pressure. Lower, block, or support any raised component with a hoist. Cover connection with heavy cloth and loosen connector nut slightly to relieve residual pressure. Catch all fluid in a container.
- Before using system, check that all connections are tight and all lines are undamaged.
- Fluid leaks can be hard to detect. Use a piece of cardboard or wood, rather than hands, to search for leaks.
- Wear protective clothing, including gloves and eye protection.

If you are injured, seek immediate medical attention from a doctor familiar with this type of injury.

Inspect Insulation (R150 units only)

Inspect heat insulation on R150 fuel tank (1) and fuel line (2) for damage every 10 hours. Replace if damaged.

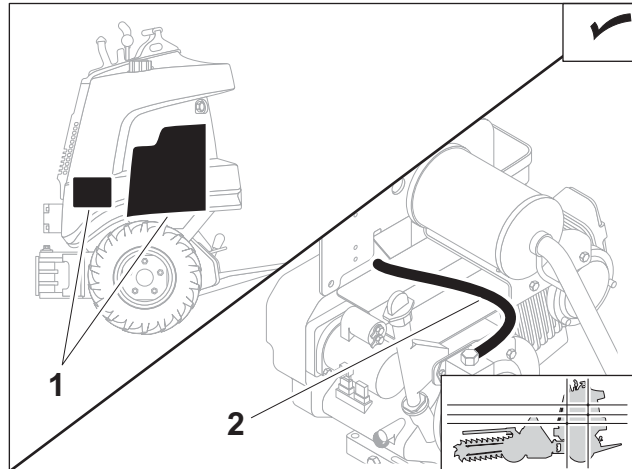

t22om001t.eps



Trencher

Lube Trencher Pivot

Lube two pivot zerks with MPG every 10 hours.

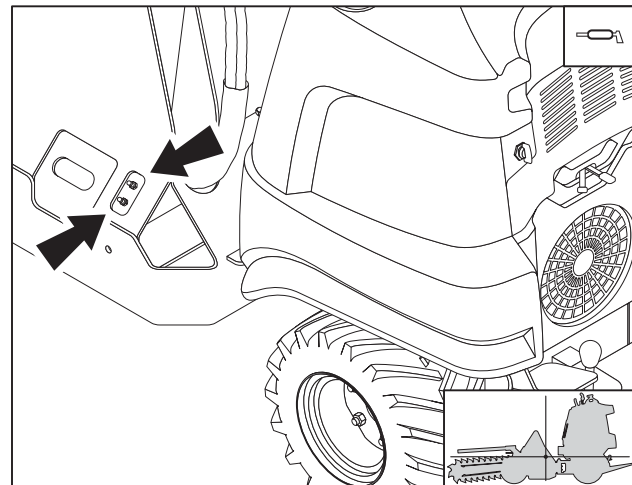

t22om057a.eps

Lube Headshaft Bearings

Lube headshaft bearing with MPG every 10 hours.

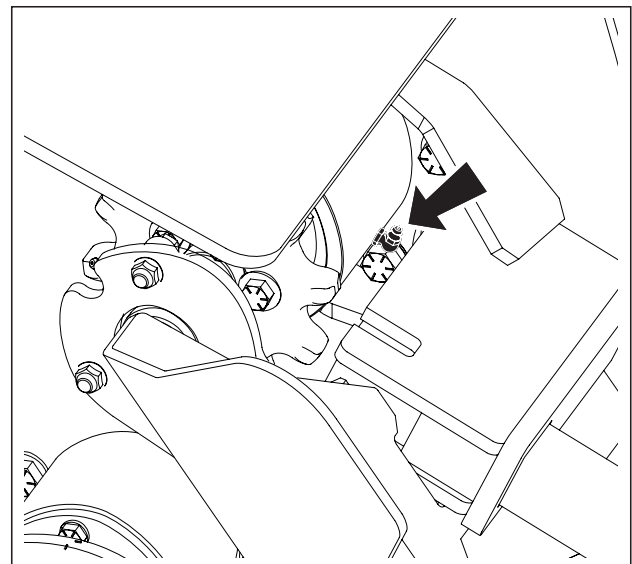

t22om001t.eps

Check Digging Chain Tension

NOTICE: Do **not** overtighten chain. Overtightening will cause chain stretch, loss of machine performance, and possible premature chain failure.

Check digging chain tension every 10 hours and adjust as needed. With boom horizontal, measure distance from bottom of boom to chain. When properly tensioned, distance (A) should be 1.5" (38 mm).

Adjustment Screw:

1. Loosen four clamp bolts (2) so that boom slides freely.
2. Loosen jam nut on adjustment screw (1).
3. To tighten digging chain, turn adjustment screw clockwise. To loosen digging chain, turn counterclockwise.
4. When proper tension is reached, tighten jam nut.
5. Tighten clamp bolts to 75 ft•lb (102 N•m).

Grease Cylinder:

To tighten digging chain, pump MPG into cylinder at check valve zerk.

To loosen digging chain, stand on opposite side of boom and unscrew check valve zerk to release grease.



WARNING Fluid pressure could pierce skin and cause injury or death. Stay away.

NOTICE: Service digging boom grease cylinder only while standing on opposite side of boom. Wear gloves and safety glasses and cover fitting with cloth when relieving pressure in cylinder.

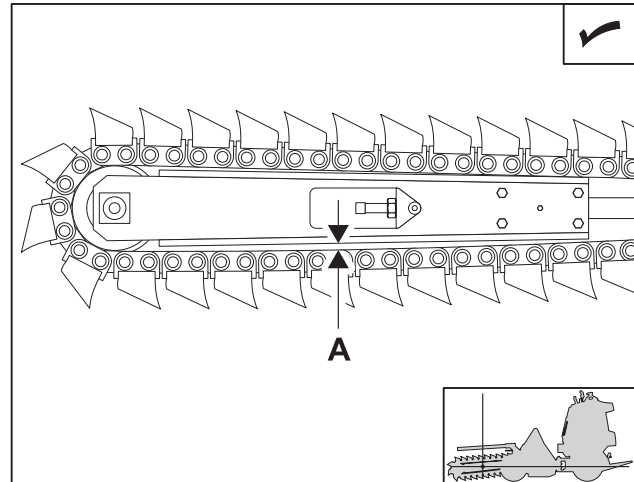

t22om058a.eps

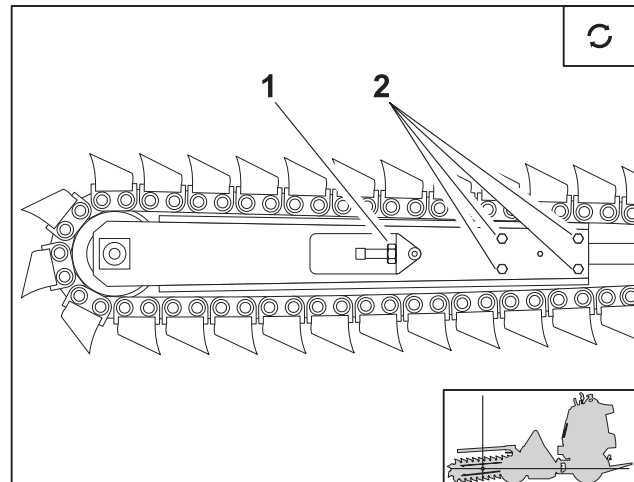

t22om059a.eps

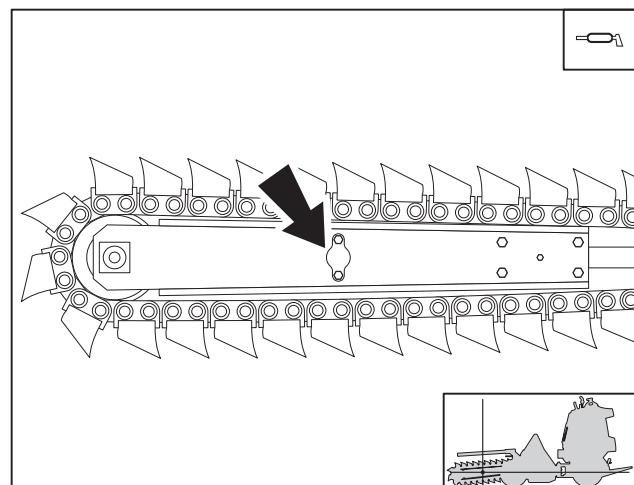

t22om060a.eps

20 Hour

Location	Task	Notes
Power Unit	Change engine oil - R150	Initial service, GEO
	Change engine oil and filter - R230/R300	Initial service, GEO
Trencher	Lube trail wheel	MPG
	Lube headshaft bearing	MPG, headshaft auger trencher only



Power Unit

Change Engine Oil (Initial) - R150

Change engine oil after the first 20 hours of operation.

1. Move drain hose (1) to front of unit and drain while oil is still warm.
2. Replace plug.
3. Add 1.6 qt (1.1 L) of GEO at fill neck (2).

IMPORTANT: If operating in extremely dusty conditions, change oil more frequently. Use oil specified in temperature chart found in "Recommended Lubricants/Service Key" on page 62.

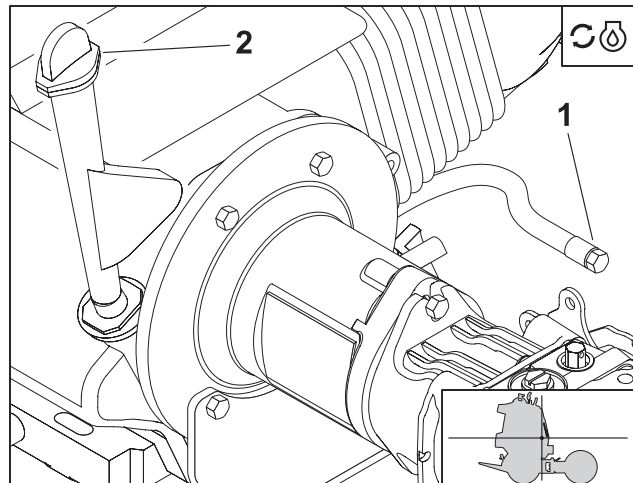

t22om045a.eps

Change Engine Oil and Filter (Initial) - R230/R300

Change engine oil and filter after the first 20 hours of operation.

1. Move drain hose (1) to front of unit and drain while oil is still warm.
2. Replace plug.
3. Install new filter (3).
4. Add 2 qt (1.9 L) of GEO at fill neck (2).

IMPORTANT: If operating in extremely dusty conditions, change oil more frequently. Use oil specified in temperature chart found in "Recommended Lubricants/Service Key" on page 62.

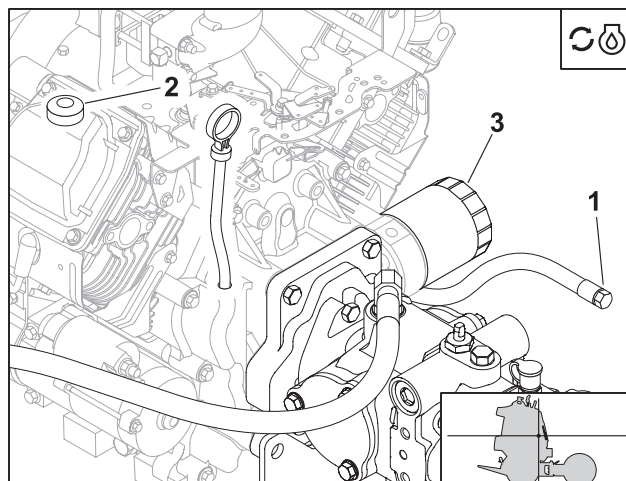

t22om046a.eps

Trencher

Lube Trail Wheel

Lube trail wheel with MPG every 20 hours.

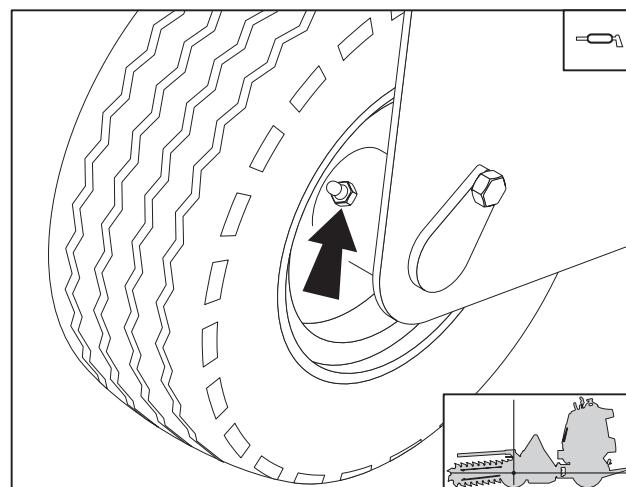

t22om061a.eps

Lube Headshaft Bearing (Headshaft Auger Trencher Only)

Lube headshaft bearing with MPG every 20 hours.

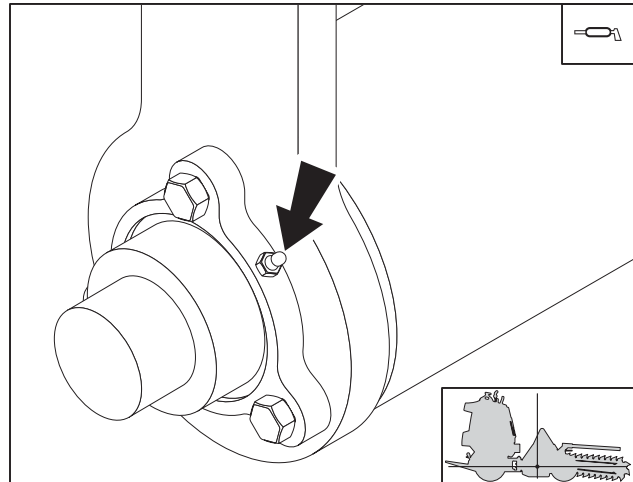

t22om062a.eps



50 Hour

Location	Task	Notes
Power Unit	Check battery	if equipped
Trencher	Lube digging boom adjustment screw and stub, if equipped	MPG
	Lube digging boom stub, if equipped	MPG

Power Unit

Check Battery

Check battery every 50 hours. Keep battery case and terminals clean. Remove all corrosion from terminals with a wire brush. Wash terminals with a weak solution of baking soda and water.

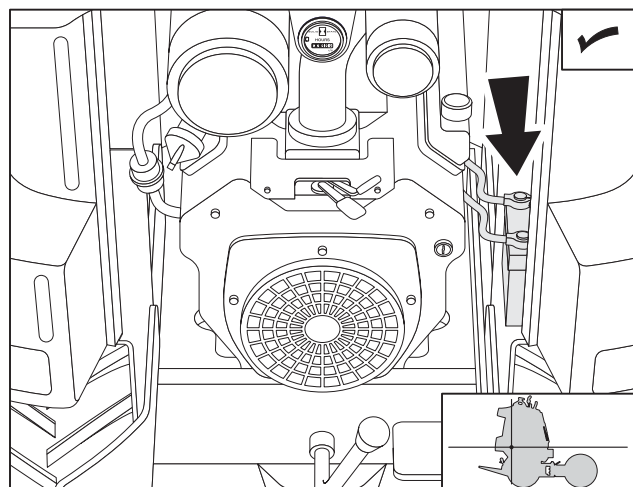

t22om047a.eps

Trencher

Lube Digging Boom Adjustment Screw and Stub

Lube adjustment screw and stub with MPG every 50 hours.

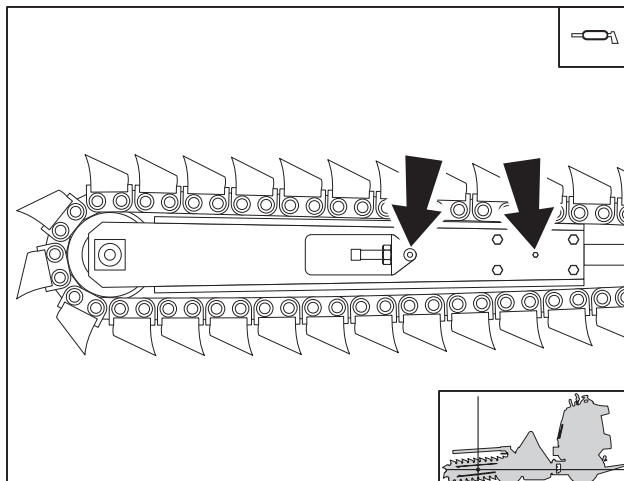

t22om063a.eps

Lube Digging Boom Stub (Greaseable Boom)

Lube boom stub with MPG every 50 hours.

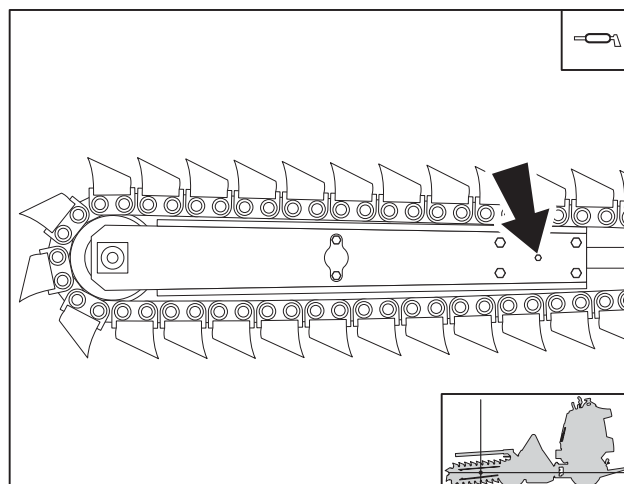

t22om064a.eps

100 Hour

Location	Task	Notes
Power Unit	Change engine oil - R150	GEO
	Change engine oil and filter - R230/R300	GEO
	Change air filter	



Power Unit

Change Engine Oil - R150

Change engine oil every 100.

1. Move drain hose (1) to front of unit and drain while oil is still warm.
2. Replace plug.
3. Add 1.6 qt (1.1 L) of GEO at fill neck (2).

IMPORTANT: If operating in extremely dusty conditions, change oil more frequently. Use oil specified in temperature chart found in "Recommended Lubricants/Service Key" on page 62.

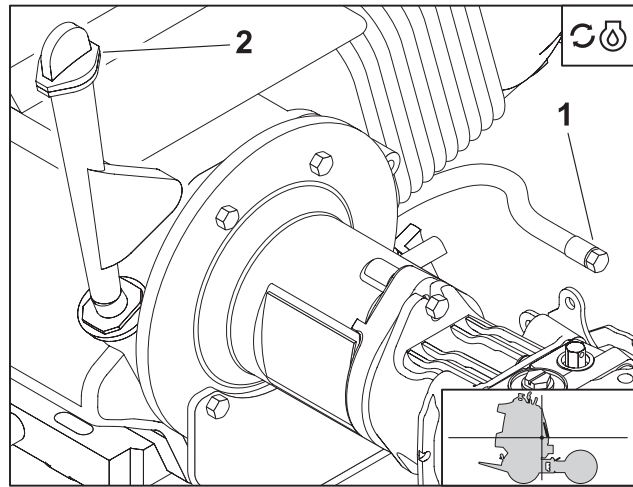

t22om045a.eps

Change Engine Oil and Filter - R230/R300

Change engine oil and filter every 100 hours.

1. Move drain hose (1) to front of unit and drain while oil is still warm.
2. Replace plug.
3. Install new filter (3).
4. Add 2 qt (1.9 L) of GEO at fill neck (2).

IMPORTANT: If operating in extremely dusty conditions, change oil more frequently. Use oil specified in temperature chart found in "Recommended Lubricants/Service Key" on page 62.

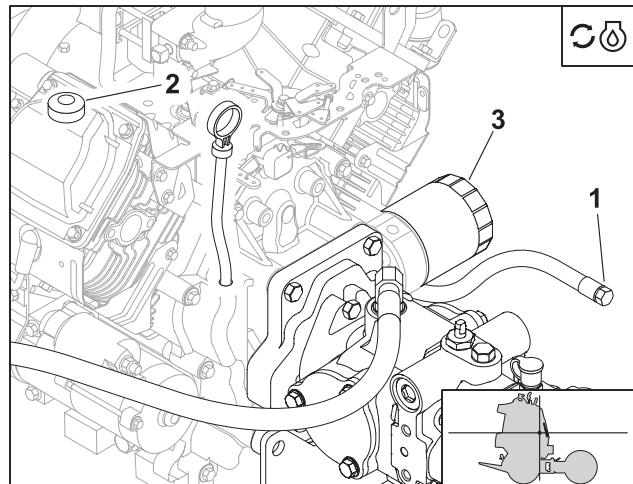

t22om046a.eps

Change Air Filter - R150

Change air filter elements every 100 hours.

IMPORTANT: If operating in extremely dusty conditions, change filter more frequently.

To change:

1. Remove wing nut (6) and air cleaner cover (5).
2. Remove wing nut (4) and remove elements (2, 3).
3. Reverse procedure to install new elements. Ensure gasket (1) is seated properly.

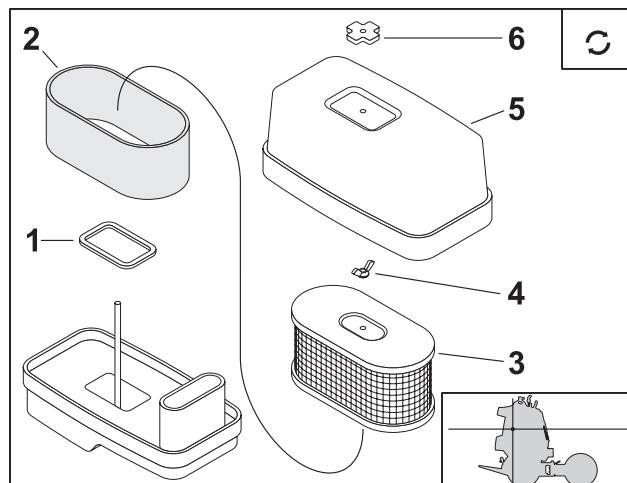

t22om051a.eps

Change Air Filter - R230/R300

Change air filter elements every 100 hours.

IMPORTANT: If operating in extremely dusty conditions, change filter more frequently.

To change:

1. Unlatch and remove air cleaner cover (1).
2. Remove elements (2, 3) and replace.
3. Reverse procedure to install.

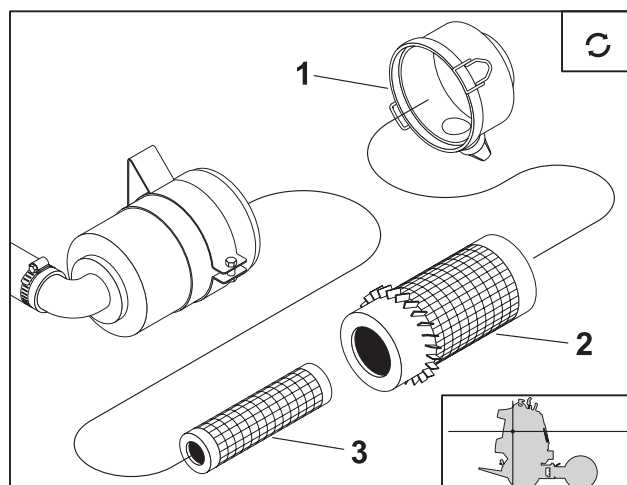

t22om052a.eps

250 Hour

Location	Task	Notes
Power Unit	Change hydraulic fluid and filter	THF
	Change fuel filter	

Power Unit

Change Hydraulic Fluid and Filter

Change hydraulic fluid and filter every 250 hours.

1. Drain hydraulic fluid at drain (3).
2. Replace plug.
3. Change filter (shown).
4. Add THF at fill neck (1, above) until level is at halfway point on sight glass (2, above).

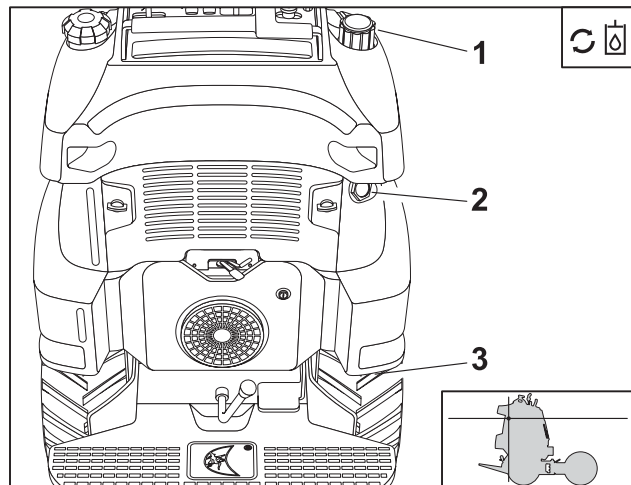

t22om050a.eps

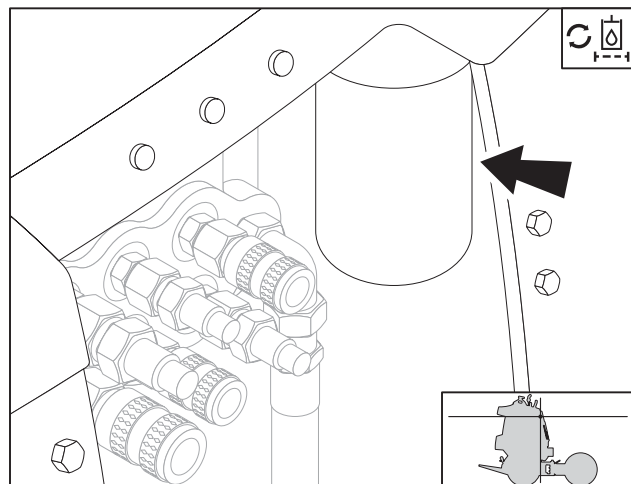

t22om048a.eps



Change Fuel Filter

Close fuel tank shutoff (top illustration) and change fuel filter (bottom illustration) every 200 hours. Open fuel tank shutoff before operating unit.

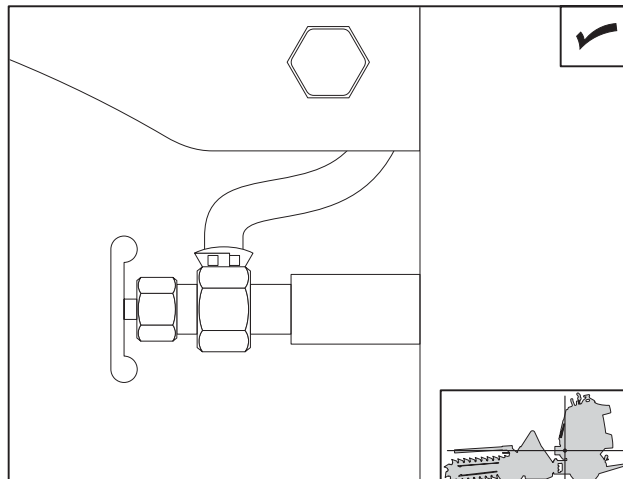

t22om090a.eps

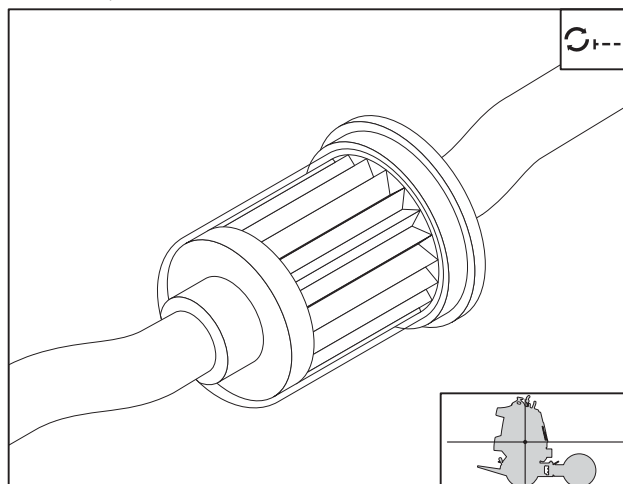

t22om049a.eps

500 Hour

Adjust Ground Drive Pump Neutral (R230/R300 only)

Adjust neutral on ground drive pump every 500 hours or if spring is rusted or worn. Check adjustment with throttle at low speed and hydraulic fluid at operating temperature. Ensure all neutral components are working properly before adjusting.

To adjust

1. Use a hoist or appropriate jack stands to raise unit until all tires are off the ground.
2. Loosen bolts (1).
3. Start unit and bring hydraulic fluid to operating temperature.
4. Adjust throttle to full speed.
5. Disengage parking brake. Tires may turn.
6. Slowly rotate cam (2) until tires stop.

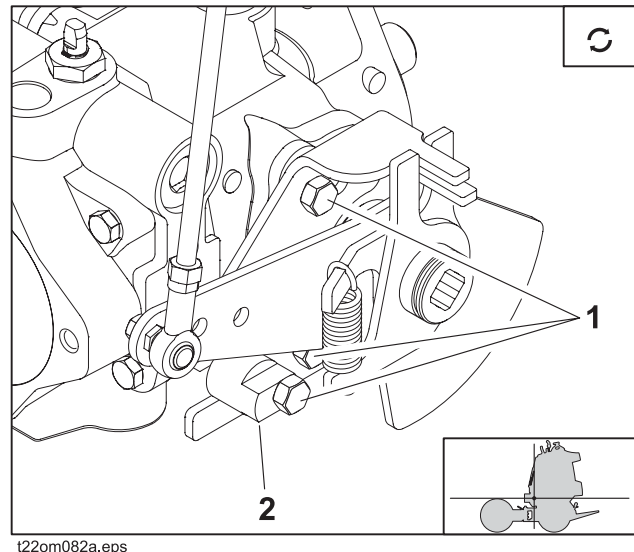

t22om082a.eps

IMPORTANT: Tires may not come to a complete stop with unit raised. Adjust to achieve the least tire movement possible.

7. Tighten bolts.
8. Engage parking brake.
9. Shut down unit.
10. Lower unit to ground.

As Needed

Location	Task	Notes
Power Unit	Change fuses	15A, 30A
	Clean cooler and screen	
	Adjust ground drive pump speed	R230/R300 only
	Adjust ground drive pump neutral	
	Set cruise control brake	
	Adjust cruise control brake	

Power Unit

Change Fuses

Change fuses as needed.

- blue with red stripe wire is 15A
- orange with blue stripe wire is 30A

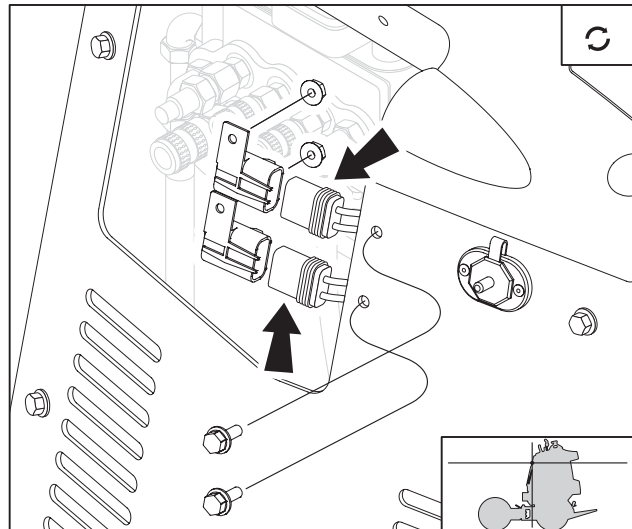

t22om084a.eps

Clean Cooler and Screen

Clean hydraulic fluid cooler and screen as needed.

IMPORTANT: All units have a cooler but only the R230 and R300 have a screen.

1. Remove bolts (1) and rear cushion (2).
2. Pop out screen (3) and clean.
3. Clean cooler fins (4) with compressed air or spray wash if required. Be careful not to damage fins with high-pressure air or water.
4. Install screen and rear cushion and secure with bolts.

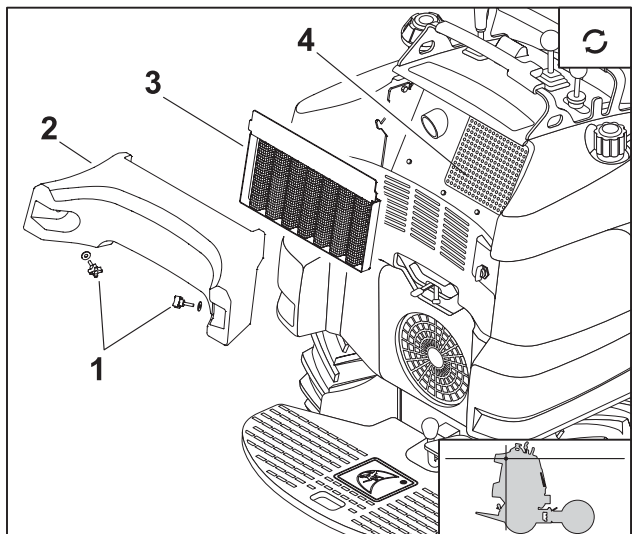

t22om084a.eps

Adjust Ground Drive Pump Speed (R230/R300 only)

Adjust ground drive pump speed as desired.

To adjust

1. Remove nut (1) and lock washer.
2. Move linkage (2) to hole that corresponds with desired speed range.
 - A is low
 - B is medium
 - C is high
3. Tighten nut.

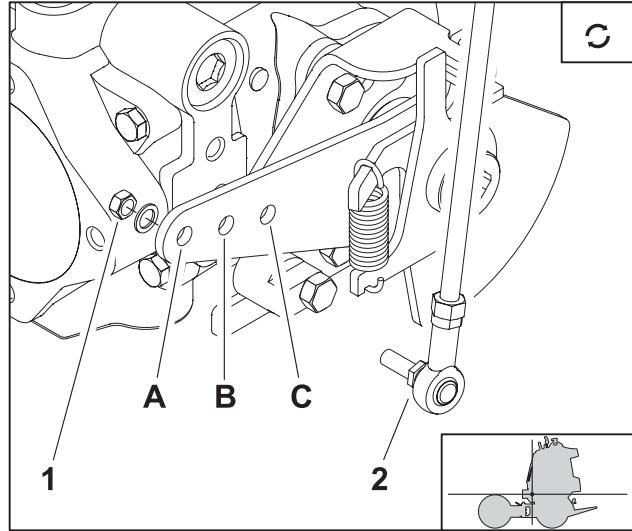

Set Cruise Control Brake

Engage or disengage cruise control brake as desired.

To engage, set arm as shown (A).

To disengage, move arm to slot (B).

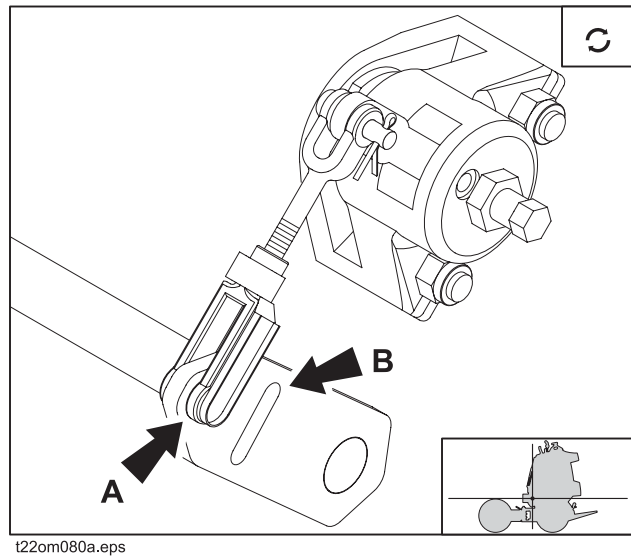

Adjust Cruise Control Brake

Adjust cruise control brake as desired. Loose brake allows more override. Tight brake allows less override.

To adjust

1. Open arm (4) and remove pin.
2. Rotate linkage (1) counterclockwise to tighten or clockwise to loosen.
3. If brake is still loose, loosen jam nut (2) and turn screw (3) clockwise to tighten and counterclockwise to loosen brake.
4. Rotate linkage as needed to adjust.
5. Reinstall arm.

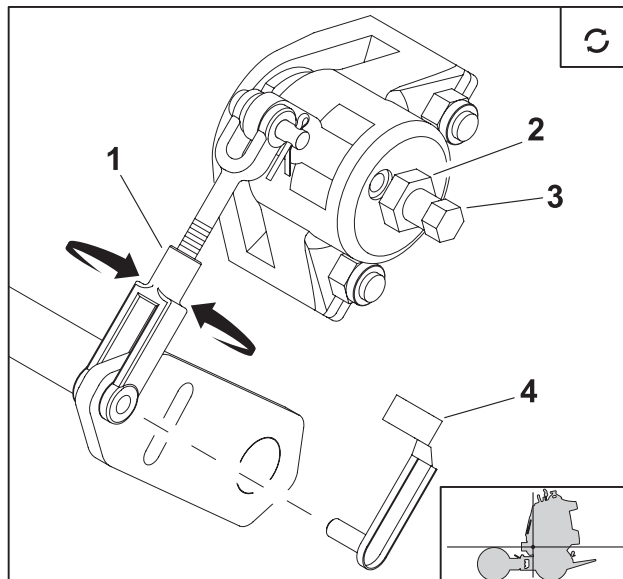

t22om079a.eps

Specifications

Chapter Contents

R150 82

R230 with InterChange Connection 85

R300 with InterChange Connection 89

Power Unit with Headshaft Auger Trencher 93

Power Unit with Independent Auger Trencher .. 96



R150

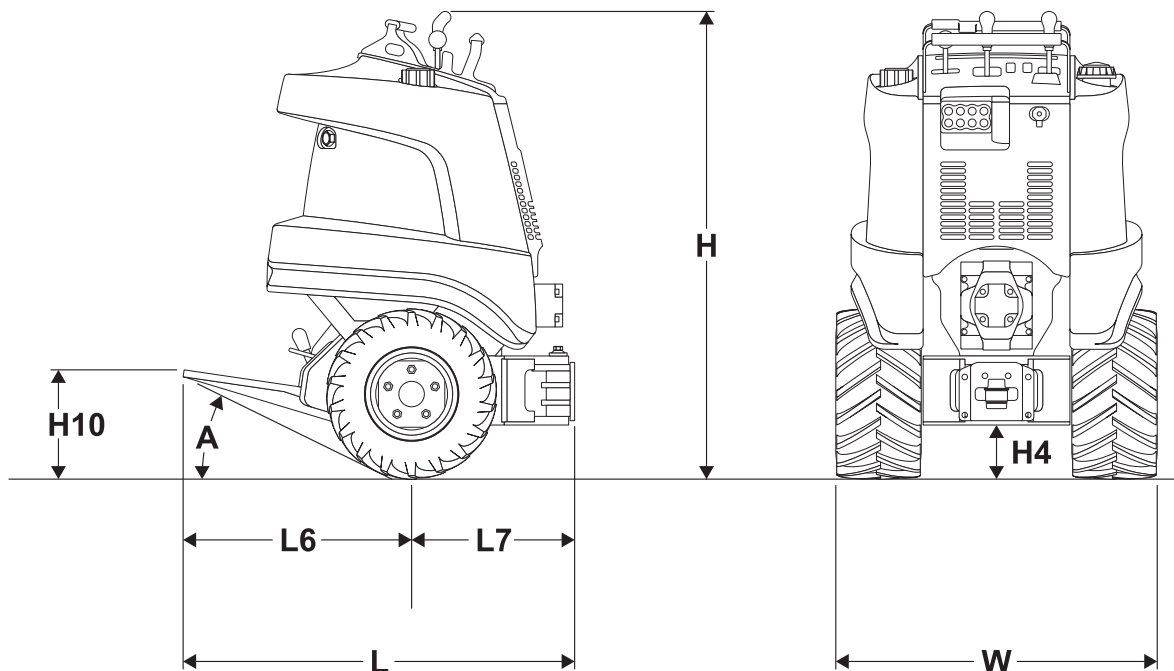

t22om000a.eps

Dimensions		U.S.	Metric
L	Length	43 in	1.09 m
L6	Tractor back to rear axle	26.8 in	681 mm
L7	Rear axle to front end mounting	19.2 in	488 mm
H	Height	53.5 in	1.36 m
H4	Ground clearance	5.3 in	135 mm
H10	Platform height	10.7 in	272 mm
W	Width	36 in	914 mm
A	Angle of departure	25°	25°

Mass

	R150	968 lb	439 kg
	R150E	1010 lb	458 kg

Vehicle clearance circle (SAE) wall to wall

	Right turn	11.3 ft	3.44 m
	Left turn	10.5 ft	3.2 m

Dimensions are based on unit equipped with urethane 18 X 9.5-8 tires unless otherwise specified.

Operation	U.S.	Metric
Ground drive speed, forward	3.3 mph	5.3 km/h
Ground drive speed, reverse	3.3 mph	5.3 km/h
Ground pressure	16 psi	1.2 bar

Power	U.S.	Metric
Engine: Honda iGX440, gasoline		
Cooling medium	air	
Number of cylinders	1	
Displacement	26.7 in ³	438 cc
Bore	3.46 in	88 mm
Stroke	2.84 in	72.1 mm
Manufacturer's power rating	15 hp	9.5 kW
Rated speed	3600 rpm	3600 rpm



Power Train

Parking brake: mechanical, hand operated

Service brake: ground drive speed/direction control brakes machine hydraulically when moved to neutral position

Tires	U.S.	Metric
18 X 9.5-8, 2 ply, bar lug		
Pressure	12 psi	82.7 kpa
Tire assembly mass	22 lb	9.98 kg
Urethane filled 18 X 9.5-8, 2 ply, bar lug		
Pressure	n/a	n/a
Tire assembly mass	36 lb	16.33 kg
18 X 8.5-8, 2 ply, turf		
Pressure	22 psi	151 kpa
Tire assembly mass	20 lb	9.07 kg

Hydraulic System	U.S.	Metric
Auxiliary: gear pump		
Flow rate	7.4 gpm	28 L/min
Pressure	3000 psi	207 bar
Ground drive: hydrostat		
Flow rate	11.4 gpm	43.2 L/min
Pressure	1800 psi	124 bar

Fluid Capacities	U.S.	Metric
Fuel tank	10.9 gal	41.3 L
Engine oil	1.6 qt	1.1 L
Hydraulic reservoir	7.7 gal	29.1 L
Total hydraulic system volume	8.5 gal	32.2 L

Battery (R150E only)

SAE reserve capacity 32 min, SAE cold crank @ 0°F (-18°C) 200 amp

Noise Levels

Operator 89 dBA sound pressure per ISO 6394
Exterior 101 dBA sound power per ISO 6393

Vibration Level

Vibration at the operator's hand during normal operation can be up to 4.1 m/sec² per ISO 5349
Vibration at the operator's foot during normal operation can be up to 8.5 m/sec² per ISO 2631

R230 with InterChange Connection

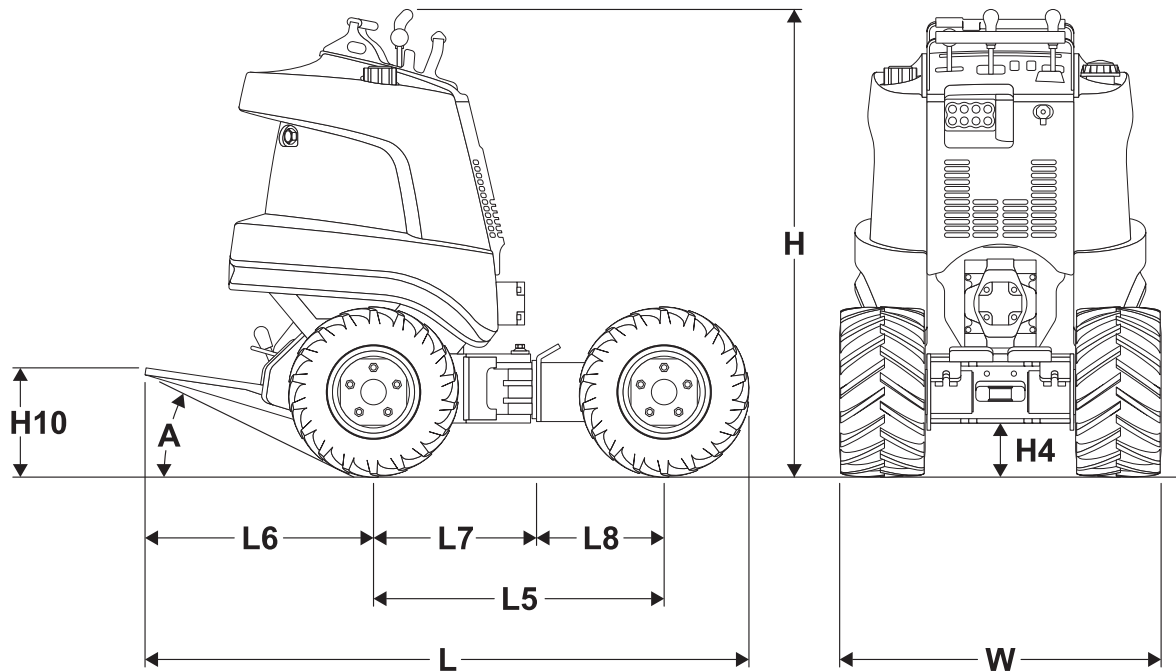

t22om001a.ens

Dimensions		U.S.	Metric
L	Driving length	70 in	1.78 m
L5	Wheelbase	34.2 in	869 mm
L6	Tractor back to rear axle	26.8 in	681 mm
L7	Rear axle to front end mounting	19.2 in	488 mm
L8	Front end mounting to front axle	15 in	381 mm
H	Height	53.5 in	1.36 m
H4	Ground clearance	5.3 in	135 mm
H10	Platform height	10.7 in	272 mm
W	Width	36 in	914 mm
A	Angle of departure	25°	25°
	Mass	1290 lb	585 kg

Vehicle clearance circle (SAE) wall to wall

	Right turn	11.3 ft	3.44 m
	Left turn	10.5 ft	3.2 m

Dimensions are based on unit equipped with urethane 18 X 9.5-8 tires unless otherwise specified.

Operation (based on 18" tires)		U.S.	Metric
Ground drive speed, forward			
	Low	3.5 mph	5.6 km/h
	High	5.0 mph	8.0 km/h
Ground drive speed, reverse			
	Low	3.5 mph	5.6 km/h
	High	5.0 mph	8.0 km/h
Ground pressure		10 psi	0.7 bar

Power		U.S.	Metric
Engine: Kohler CH23S, gasoline			
Cooling medium		air	
Number of cylinders		2	
Displacement		41.1 in ³	674 cc
Bore		3.15 in	80 mm
Stroke		2.64 in	67 mm
Manufacturer's power rating		23 hp	17.2 kW
Rated speed		3600 rpm	3600 rpm

Power Train

Parking brake: mechanical, hand operated

Service brake: ground drive speed/direction control brakes machine hydraulically when moved to neutral position

Tires		U.S.	Metric
18 X 9.5-8, 2 ply, bar lug			
	Pressure	12 psi	82.7 kpa
	Tire assembly mass	22 lb	9.98 kg
Urethane filled 18 X 9.5-8, 2 ply, bar lug			
	Pressure	n/a	n/a
	Tire assembly mass	36 lb	16.33 kg
Urethane filled 20 X 10-8, 4 ply, bar lug			
	Pressure	n/a	n/a
	Tire assembly mass	49 lb	22.23 kg
18 X 8.5-8, 2 ply, 2 turf			
	Pressure	22 psi	151 kpa
	Tire assembly mass	20 lb	9.07 kg
Hydraulic System		U.S.	Metric
Auxiliary: gear pump			
	Flow rate	12 gpm	46 L/min
	Pressure	3000 psi	207 bar
Ground drive: hydrostat			
	Flow rate	19.3 gpm	73 L/min
	Pressure	3500 psi	241 bar



Fluid Capacities	U.S.	Metric
Fuel tank	10.9 gal	41.3 L
Engine oil, with filter	2 qt	1.9 L
Hydraulic reservoir	7.7 gal	29.1 L
Total hydraulic system volume	8.5 gal	32.2 L

Battery

SAE reserve capacity 32 min, SAE cold crank @ 0°F (-18°C) 200 amp

Noise Levels

Operator 90 dBA sound pressure per ISO 6394
Exterior 102 dBA sound power per ISO 6393

Vibration Level

Vibration at the operator's hand during normal operation can be up to 9.9 m/sec² per ISO 5349
Vibration at the operator's foot during normal operation can be up to 8.5 m/sec² per ISO 2631

R300 with InterChange Connection

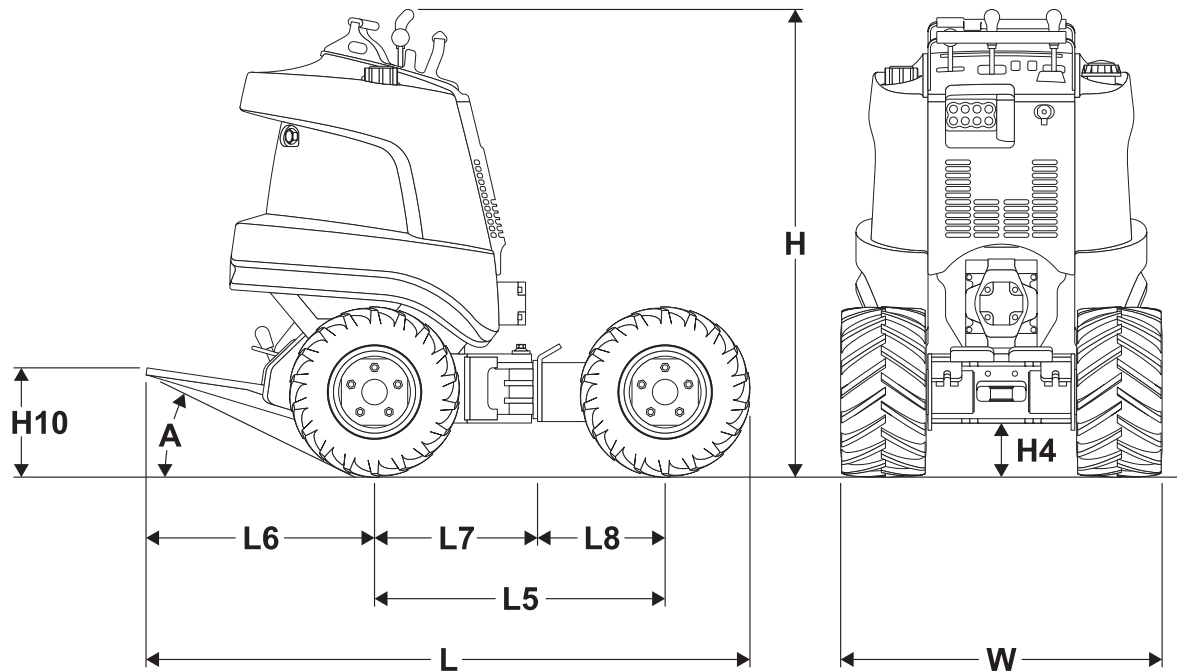

t22om001a.ens

Dimensions		U.S.	Metric
L	Driving length	70 in	1.78 m
L5	Wheelbase	34.2 in	869 mm
L6	Tractor back to rear axle	26.8 in	681 mm
L7	Rear axle to front end mounting	19.2 in	488 mm
L8	Front end mounting to front axle	15 in	381 mm
H	Height	53.5 in	1.36 m
H4	Ground clearance	5.3 in	135 mm
H10	Platform height	10.7 in	272 mm
W	Width	36 in	914 mm
A	Angle of departure	25°	25°
	Mass	1290 lb	585 kg

Vehicle clearance circle (SAE) wall to wall

	Right turn	11.3 ft	3.44 m
	Left turn	10.5 ft	3.2 m

Dimensions are based on unit equipped with urethane 18 X 9.5-8 tires unless otherwise specified.

Operation (based on 18" tires)		U.S.	Metric
Ground drive speed, forward			
	Low	3.5 mph	5.6 km/h
	High	5.0 mph	8.0 km/h
Ground drive speed, reverse			
	Low	3.5 mph	5.6 km/h
	High	5.0 mph	8.0 km/h
Ground pressure		10 psi	0.7 bar

Power		U.S.	Metric
Engine: Kohler CH750S, gasoline			
Cooling medium		air	
Number of cylinders		2	
Displacement		45.6 in ³	747 cc
Bore		3.3 in	83 mm
Stroke		2.7 in	69 mm
Manufacturer's power rating		30 hp	22.4 kW
Rated speed		3600 rpm	3600 rpm

Power Train

Parking brake: mechanical, hand operated

Service brake: ground drive speed/direction control brakes machine hydraulically when moved to neutral position

Tires		U.S.	Metric
18 X 9.5-8, 2 ply, bar lug			
	Pressure	12 psi	82.7 kpa
	Tire assembly mass	22 lb	9.98 kg
Urethane filled 18 X 9.5-8, 2 ply, bar lug			
	Pressure	n/a	n/a
	Tire assembly mass	36 lb	16.33 kg
Urethane filled 20 X 10-8, 4 ply, bar lug			
	Pressure	n/a	n/a
	Tire assembly mass	49 lb	22.23 kg
18 X 8.5-8, 2 ply, turf			
	Pressure	22 psi	151 kpa
	Tire assembly mass	20 lb	9.07 kg
Hydraulic System		U.S.	Metric
Auxiliary: gear pump			
	Flow rate	12 gpm	46 L/min
	Pressure	3000 psi	207 bar
Ground drive: hydrostat			
	Flow rate	19.3 gpm	73 L/min
	Pressure	3500 psi	241 bar



Fluid Capacities	U.S.	Metric
Fuel tank	10.9 gal	41.3 L
Engine oil, with filter	2 qt	1.9 L
Hydraulic reservoir	7.7 gal	29.1 L
Total hydraulic system volume	8.5 gal	32.2 L

Battery

SAE reserve capacity 32 min, SAE cold crank @ 0°F (-18°C) 200 amp

Noise Levels

Operator 90 dBA sound pressure per ISO 6394
Exterior 103 dBA sound power per ISO 6393

Vibration Level

Vibration at the operator's hand during normal operation can be up to 9.9 m/sec² per ISO 5349
Vibration at the operator's foot during normal operation can be up to 8.5 m/sec² per ISO 2631

Power Unit with Headshaft Auger Trencher

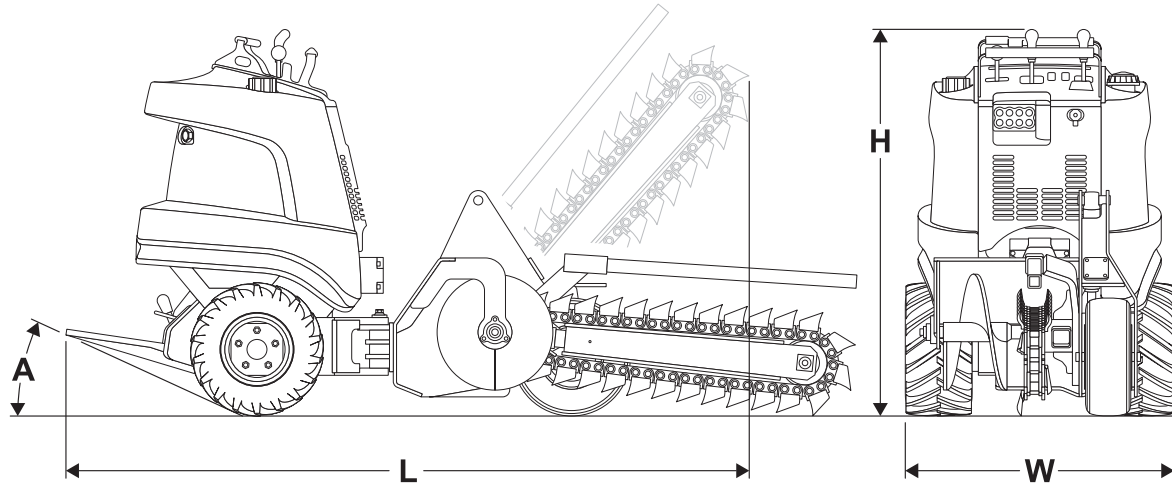

t22om020a.eps

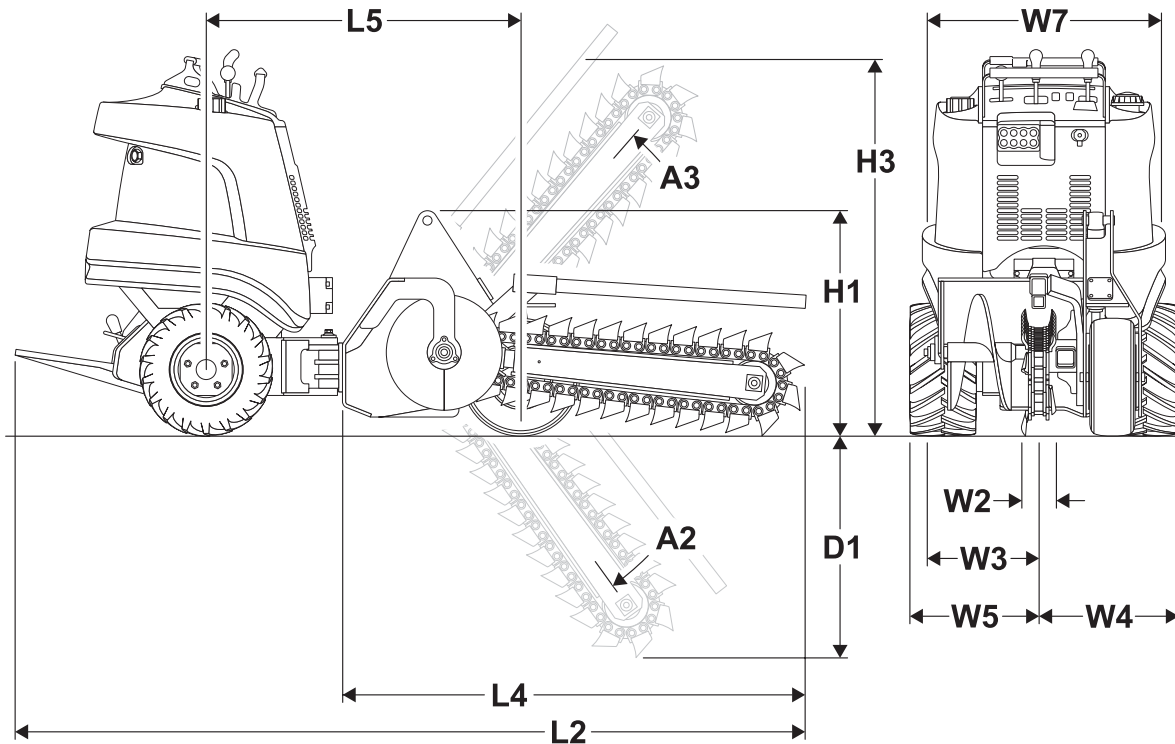

t22om021a.eps

Dimensions		U.S.	Metric
L	Driving length	90.5 in	2.3 m
L2	Maximum length	104.5 in	2.65 m
L4	Front end length	58.5 in	1.49 m
L5	Wheelbase	44.2 in	1.12 m



Dimensions		U.S.	Metric
H	Driving height	53.5 in	1.36 m
H1	Tie-down height	31.7 in	805 mm
H3	Maximum front end height	49.3 in	1.25 m
D1	Operating depth (maximum)	36 in	914 mm
W	Width	36 in	914 mm
W2	Cutting width	4-8 in	102-203 mm
W3	Spoils width	13.8 in	351 mm
W4	Centerline of trench, left	18.5 in	470 mm
W5	Centerline of trench, right	17.5 in	445 mm
W7	Front end width	34 in	864 mm
A	Angle of departure	25°	25°
A2	Front end travel down (recommended)	60°	60°
A3	Front end travel up (recommended)	50°	50°
Unit mass		1468 lb	652.3 kg
Front end mass w/24" boom and 4" cup tooth chain		420 lb	190.5 kg
Vehicle clearance circle (SAE) wall to wall			
	Right turn	11.3 ft	3.44 m
	Left turn	10.2 ft	3.11 m

Headshaft Speeds @ 3600 engine rpm		U.S.	Metric
R150			
Medium speed/medium torque		149 rpm	149 rpm
High speed/low torque		183 rpm	183 rpm
R230/R300			
Low speed/high torque		186 rpm	186 rpm
Medium speed/medium torque		244 rpm	244 rpm

Power Train	U.S.	Metric
Digging chain drive: hydraulic direct drive		
Digging chain: 33,000 lb or 35,000 lb		
Spoils handling drive: mechanical, attaches to the headshaft		
Chain drive sprocket: forged and tempered		

Operation	U.S.	Metric
Digging chain speed		
Minimum	290 ft/min	88.4 m/min
Maximum	364 ft/min	111 m/min
Trench cleaner (optional) type: mechanical		
Minimum	4 in	102 mm
Maximum	8 in	203 mm
Spoils handling: single open end auger		
Auger size: 18" OD x 2" ID x 8.7" long		

Tires	U.S.	Metric
Trail wheel: urethane filled 16 X 6.5-8, 2 ply, bar lug		
Tire assembly mass	18 lb	8.16 kg



Power Unit with Independent Auger Trencher

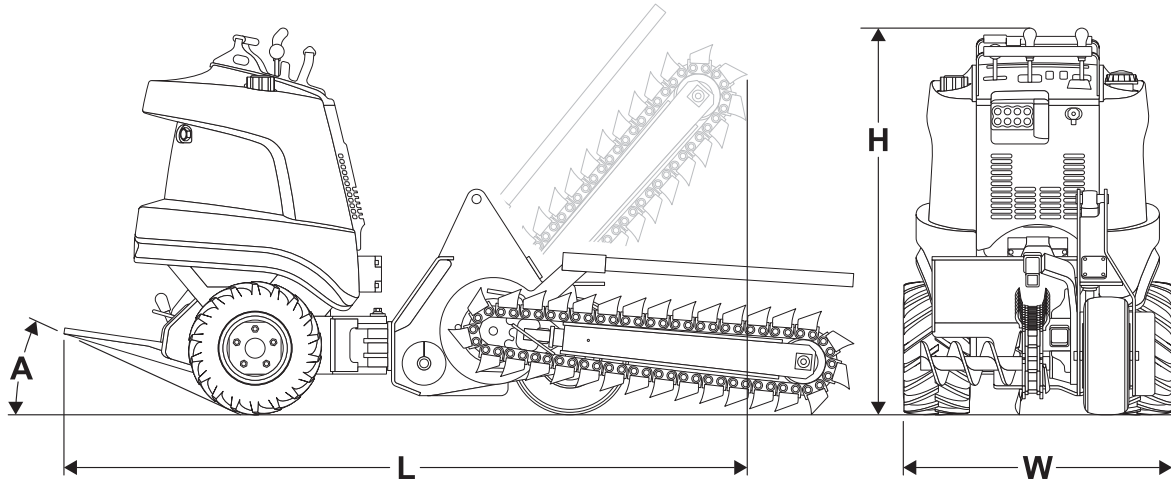

t22om018a.eps

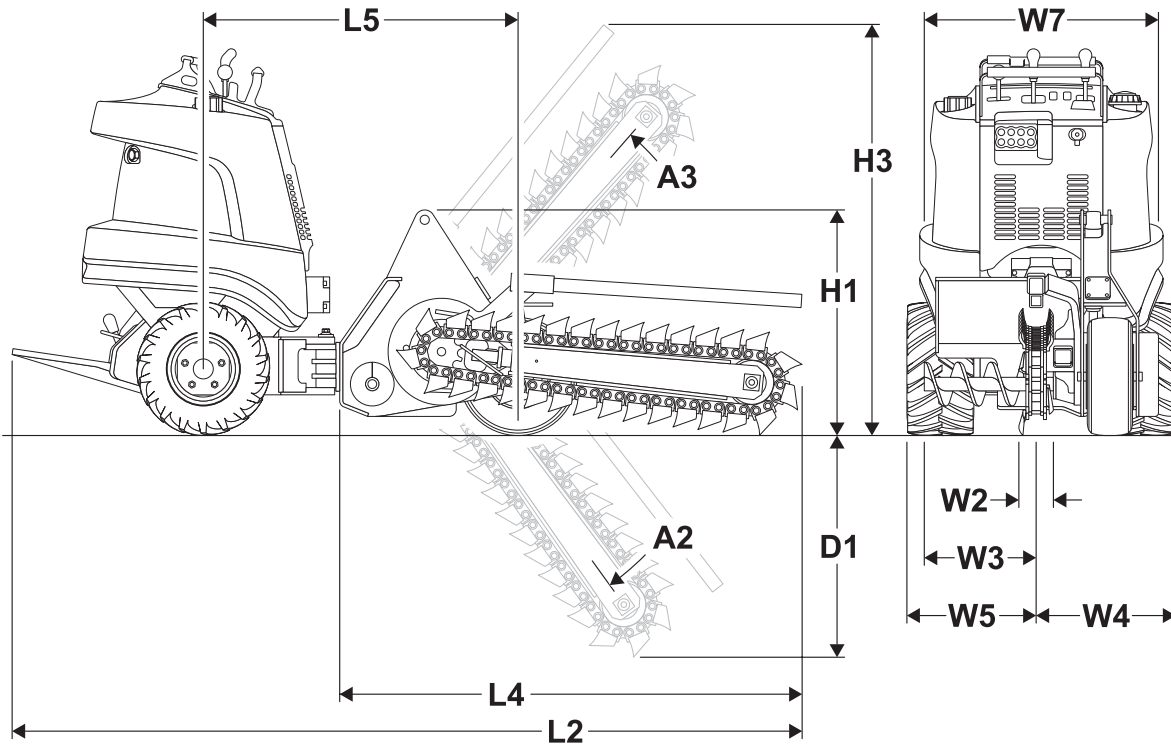

t22om019a.eps

Dimensions		U.S.	Metric
L	Driving length	90.5 in	2.3 m
L2	Maximum length	104.5 in	2.65 m
L4	Front end length	58.5 in	1.49 m
L5	Wheelbase	44.2 in	1.12 m

Dimensions		U.S.	Metric
H	Driving height	53.5 in	1.36 m
H1	Tie-down height	31.7 in	805 mm
H3	Maximum front end height	49.3 in	1.25 m
D1	Operating depth (maximum)	36 in	914 mm
W	Width	36 in	914 mm
W2	Cutting width	4-8 in	102-203 mm
W3	Spoils width	16 in	406 mm
W4	Centerline of trench, left	18.5 in	470 mm
W5	Centerline of trench, right	17.5 in	445 mm
W7	Front end width	33 in	838 mm
A	Angle of departure	25°	25°
A2	Front end travel down (recommended)	60°	60°
A3	Front end travel up (recommended)	50°	50°
Unit mass		1488 lb	674.9 kg
Front end mass w/24" boom and 4" cup tooth chain		440 lb	199.6 kg
Vehicle clearance circle (SAE) wall to wall			
	Right turn	11.3 ft	3.44 m
	Left turn	10.5 ft	3.2 m



Headshaft Speeds @ 3600 engine rpm		U.S.	Metric
R150			
Medium speed/medium torque		149 rpm	149 rpm
High speed/low torque		183 rpm	183 rpm
R230/R300			
Low speed/high torque		186 rpm	186 rpm
Medium speed/medium torque		244 rpm	244 rpm

Power Train	U.S.	Metric
-------------	------	--------

Digging chain drive: hydraulic direct drive
 Digging chain: 33,000 lb or 35,000 lb
 Spoils handling drive: hydraulic, independent
 Chain drive sprocket: forged and tempered

Operation		U.S.	Metric
Digging chain speed			
	Minimum	230 ft/min	70.1 m/min
	Maximum	364 ft/min	111 m/min
Trench cleaner (optional) type: mechanical			
	Minimum	4 in	102 mm
	Maximum	8 in	203 mm
Spoils handling: single open end auger			
Auger size: 6.18" OD x 2" ID x 17.25" long			
Tires			
Trail wheel: urethane filled 16 X 6.5-8, 2 ply, bar lug			
Tire assembly mass		18 lb	8.16 kg

Specifications are called out according to SAE recommended procedures. Specifications are general and subject to change without notice. If exact measurements are required, equipment should be weighed and measured. Due to selected options, delivered equipment may not necessarily match that described.

Support

Procedure

Notify your dealer immediately of any malfunction or failure of Ditch Witch equipment.

Always give model, serial number, and approximate date of your equipment purchase. This information should be recorded and placed on file by the owner at the time of purchase.

Return damaged parts to dealer for inspection and warranty consideration if in warranty time frame.

Order genuine Ditch Witch replacement or repair parts from your authorized Ditch Witch dealer. Use of another manufacturer's parts may void warranty consideration.

Resources



Publications

Contact your Ditch Witch dealer for publications and videos covering safety, operation, service, and repair of your equipment.

Ditch Witch Training

For information about on-site, individualized training, contact your Ditch Witch dealer.

Warranty

Ditch Witch Equipment and Replacement Parts Limited Warranty Policy

Subject to the limitation and exclusions herein, free replacement parts will be provided at any authorized Ditch Witch dealership for any Ditch Witch equipment or parts manufactured by The Charles Machine Works, Inc. (CMW) that fail due to a defect in material or workmanship within one (1) year of first commercial use (Exception: 2 years for all SK5 attachments). Free labor will be provided at any authorized Ditch Witch dealership for installation of parts under this warranty during the first year following "initial commercial" use of the serial-numbered Ditch Witch equipment on which it is installed. The customer is responsible for transporting their equipment to an authorized Ditch Witch dealership for all warranty work.

Exclusions from Product Warranty

- All incidental or consequential damages.
- All defects, damages, or injuries caused by misuse, abuse, improper installation, alteration, neglect, or uses other than those for which products were intended.
- All defects, damages, or injuries caused by improper training, operation, or servicing of products in a manner inconsistent with manufacturer's recommendations.
- All engines and engine accessories (these are covered by original manufacturer's warranty).
- Tires, belts, and other parts which may be subject to another manufacturer's warranty (such warranty will be available to purchaser).
- ALL IMPLIED WARRANTIES NOT EXPRESSLY STATED HEREIN, INCLUDING ANY WARRANTY OF FITNESS FOR A PARTICULAR PURPOSE AND MERCHANTABILITY.

IF THE PRODUCTS ARE PURCHASED FOR COMMERCIAL PURPOSES, AS DEFINED BY THE UNIFORM COMMERCIAL CODE, THEN THERE ARE NO WARRANTIES WHICH EXTEND BEYOND THE FACE HEREOF AND THERE ARE NO IMPLIED WARRANTIES OF ANY KIND WHICH EXTEND TO A COMMERCIAL BUYER. ALL OTHER PROVISIONS OF THIS LIMITED WARRANTY APPLY INCLUDING THE DUTIES IMPOSED.

Ditch Witch products have been tested to deliver acceptable performance in most conditions. This does not imply they will deliver acceptable performance in all conditions. Therefore, to assure suitability, products should be operated under anticipated working conditions prior to purchase.

Defects will be determined by an inspection within thirty (30) days of the date of failure of the product or part by CMW or its authorized dealer. CMW will provide the location of its inspection facilities or its nearest authorized dealer upon inquiry. CMW reserves the right to supply remanufactured replacement parts under this warranty as it deems appropriate.

Extended warranties are available upon request from your local Ditch Witch dealer or CMW.

Some states do not allow exclusion or limitation of incidental or consequential damages, so above limitation of exclusion may not apply. Further, some states do not allow exclusion of or limitation of how long an implied warranty lasts, so the above limitation may not apply. This limited warranty gives product owner specific legal rights and the product owner may also have other rights which vary from state to state.

For information regarding this limited warranty, contact CMW's Product Support department, P.O. Box 66, Perry, OK 73077-0066, or contact your local Ditch Witch dealer.

First version: 1/91; Latest version: 7/05

**A Note To
Ditch Witch
Equipment Owners:**

If your equipment was purchased through a Ditch Witch dealer, there is no need to read further.

However, if you purchased from any other source, please fill out the form on the reverse side and return it to us.

This will enable you to receive updates on this equipment as well as information on new products of interest.

Thanks for using Ditch Witch equipment.

(Please Fold Along This Line And Seal At Bottom With Tape)



NO POSTAGE
NECESSARY
IF MAILED
IN THE
UNITED STATES

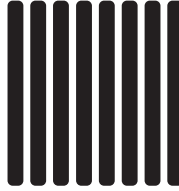

BUSINESS REPLY MAIL

FIRST CLASS PERMIT NO. 23 PERRY OKLAHOMA

POSTAGE WILL BE PAID BY

**The Charles Machine Works, Inc.
P.O. Box 66
Perry, Oklahoma 73077-9989**



**A Note To
Ditch Witch
Equipment Owners:**

If your equipment was purchased through a Ditch Witch dealer, there is no need to read further.

However, if you purchased from any other source, please fill out the form on the reverse side and return it to us.

This will enable you to receive updates on this equipment as well as information on new products of interest.

Thanks for using Ditch Witch equipment.

(Please Fold Along This Line And Seal At Bottom With Tape)



NO POSTAGE
NECESSARY
IF MAILED
IN THE
UNITED STATES

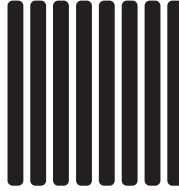

BUSINESS REPLY MAIL

FIRST CLASS PERMIT NO. 23 PERRY OKLAHOMA

POSTAGE WILL BE PAID BY

**The Charles Machine Works, Inc.
P.O. Box 66
Perry, Oklahoma 73077-9989**



Ditch Witch® Registration Card

Please Type or Print All Information

Purchaser's Company Name

Attention

Street Address or P.O. Box

City County

State Zip Nation

()

Phone Number With Area Code

Model Serial Number

Attachments/Accessories Serial Numbers

Attachments/Accessories Serial Numbers

Attachments/Accessories Serial Numbers

Name of Ditch Witch Dealership

Your Signature

Ditch Witch® Registration Card

Please Type or Print All Information

Purchaser's Company Name

Attention

Street Address or P.O. Box

City County

State Zip Nation

()

Phone Number With Area Code

Model Serial Number

Attachments/Accessories Serial Numbers

Attachments/Accessories Serial Numbers

Attachments/Accessories Serial Numbers

Name of Ditch Witch Dealership

Your Signature

